



RAUPIANO PLUS

THE VERSATILE ACOUSTIC DRAINAGE SYSTEM

TECHNICAL INFORMATION



TABLE OF CONTENTS

1	Information and safety recommendations	4	7	Attachment of RAUPIANO PLUS	22
2	System description	5	7.1	Support bracket for vertical stack	22
2.1	Function	5	7.2	Fixing plan for vertical stack	23
2.1.1	Residential buildings	5	7.3	Bracketing plan for horizontal pipes	24
2.1.2	Commercial buildings	5	7.4	Short pipes and fittings	24
2.1.3	Installation underground	5	8	Laying underground	25
2.1.4	Commercial kitchens	5	8.1	General	25
2.1.5	VACUCLEAN central vacuum cleaner system	5	8.2	Pipe trench	25
2.2	Application	6	8.3	Embedment	26
2.3	Pipe structure	6	8.3.1	Embedment materials	26
2.4	Fittings	7	8.3.2	Pipe bedding	26
2.5	Sound insulation	7	8.3.3	Filling	27
2.6	System components	7	8.3.4	Compacting	27
2.7	Form of delivery and storage	8	8.4	Building connections	27
2.8	Marking	8	8.5	Leak test	27
2.9	Recycling	8	9	Certifications	28
3	Sound insulation	9	10	Technical specifications	29
3.1	Sound-insulation requirements	9	11	Chemical resistance	30
3.2	Basics	10	12	Standards, regulations and guidelines	35
3.3	Sound reduction with RAUPIANO PLUS	11			
3.4	Laboratory testing of the sound-insulation behaviour	12			
3.5	Measurement results	12			
4	Fire protection	13			
4.1	Fire-protection requirements	13			
4.2	Fireproofing collars	13			
5	Design and planning	14			
5.1	Measurement basics	14			
5.2	Assembly times	14			
5.3	Specification	15			
6	Assembly of RAUPIANO PLUS	16			
6.1	Shortening and tapering pipes	16			
6.2	Joining fittings and pipes	16			
6.3	Handling cut lengths and remaining lengths	17			
6.4	Installation of additional fittings	17			
6.5	Connecting drain fitting	17			
6.6	Connection pieces for cast iron pipes/other materials	18			
6.7	Adapting to PVC system	18			
6.8	Flexible connection to roof vent	19			
6.9	Cleaning the waste pipe system	19			
6.10	Socket plug	19			
6.11	P-traps	20			
6.12	Floor trap	20			
6.13	Installing pipes in installation shafts	20			
6.14	Installing pipes in masonry	20			
6.15	Installing pipes in concrete	21			
6.16	Installation above suspended ceilings	21			
6.17	Ceiling penetrations	21			
6.18	Installation as stormwater piping	21			

1 INFORMATION AND SAFETY RECOMMENDATIONS

Notes on this technical information

Applicability

This technical information is applicable for GCC, Middle East and Iran.

Navigation

A detailed table of contents with hierarchical titles and the corresponding page numbers is found at the beginning of each chapter.

Pictograms and logos



Safety recommendation



Legal note



Important information must be heeded



Information on the Internet



Advantage



Please check at regular intervals whether a more recent version of this technical information is available for your own safety and to ensure correct usage of our products.

The date of issue of your technical information is always printed at the bottom left on the cover page.

The current technical information is available from your REHAU sales office, specialist wholesaler as well as on the Internet as a download at: www.rehau.ae



- Read the safety recommendations and operating instructions carefully and completely for your own safety and for the safety of other people before starting with assembly.
- Retain the operating instructions and keep them handy.
- If you do not understand the safety recommendations or individual assembly instructions, or if they are unclear, contact your REHAU sales office.

Intended use

The domestic waste water system RAUPIANO PLUS may only be installed and operated as described in this technical information.

Any other use is unintended and therefore impermissible.



General precautionary measures

- Observe the generally applicable accident prevention and safety regulations when installing piping systems.
- Keep the work area clean and free of impeding objects.
- Provide sufficient lighting at the work area.
- Keep children, house pets and unauthorised persons away from tools and the places of assembly. This is especially important in cases of renovation in inhabited areas.
- Use only the intended components for the respective pipe system. The use of components or tools from other companies which are not from the respective installation system from REHAU can lead to accidents or other dangers.

Fire protection

Observe the applicable fire-protection regulations very carefully as well as the codes/regulations of building practice that apply in each case, especially in relation to:

- Penetrating through fire compartments.
- For rooms subject to the guideline on places of public assembly.

Personnel requirements

- Allow only authorised and trained persons to assemble our systems.
- Work on electrical systems or pipe components may only be performed by persons trained and authorised for this purpose.

Work clothing

- Wear protective glasses, suitable work clothing, safety shoes, a protective helmet and, if you have long hair, a hairnet.
- Do not wear loose clothing or jewellery. They could be caught by moving parts.
- Wear a protective helmet when performing assembly work at head level or above your head.

When assembling the system

- Always read and comply with the respective operating instructions of the assembly tool used.
- The cutting tools have a sharp blade. The cutting tools are to be stored and handled in a safe way to prevent injuries.
- When shortening pipes, maintain a safe distance between the hand holding the object and the cutting tool.
- Never put your hands near the area where the tool is cutting or on moving parts.
- When performing service, maintenance and conversion work and when changing the place of assembly, always unplug the power plug of the tool and secure it against being switched on inadvertently.

2 SYSTEM DESCRIPTION

2.1 Function

RAUPIANO PLUS is a universal sound-insulating sewer pipe system for non-pressurised site drainage in accordance with DIN EN 12056, DIN EN 752 and DIN 1986-100. It can be used as a universal drainage system for everything from one-family houses to large buildings.

RAUPIANO PLUS is available in nominal sizes from DN 40 to DN 200. Comprehensive fitting, adaptor and bracket range complete the system. They are characterized by the following features:



- Excellent sound-insulation properties
 - Mineral filled material for pipes and fitting to reduce air-borne noise
 - Partially thickened walls for bend fittings to improve air-borne sound insulation
 - Special sound-dampening bracket to reduce transmission of structure-borne noise
- Fast and easy installation
- The joint is designed to absorb any thermal expansion
- Pipes and fittings come with built-in sockets, no double socket is required for jointing
- High quality product
 - Excellent impact resistance - robust for transport, storage and handling at construction site
 - High UV-resistance, can be stored outdoor for 2 years (for Central Europe).
 - Smooth yet abrasion-resistance inner layer to reduce risk of deposits and scaling
- Green material, non-toxic material without halogen

2.1.1 Residential buildings

RAUPIANO PLUS is the universal system for non-pressurised drainage in accordance with DIN EN 12056 and DIN 1986-100 in building construction, both as a standard drainage system without specialised sound-protection requirements and with elevated sound-protection demands (VDI guideline 4100).

For example in:

- One-family house
- Multistorey apartment block
- Condominiums

2.1.2 Commercial buildings

RAUPIANO PLUS can also be installed in buildings with elevated sound-protection requirements (VDI guideline 4100). Thanks to its high sound-insulation properties, RAUPIANO PLUS is especially suitable for:

- Hotels
- Office buildings
- Hospitals

RAUPIANO PLUS meets the increasing need for peace and quiet and ensures a high level of living comfort.

The pipe dimensions in accordance with DIN EN 1451 allow trouble-free transition to HT in accordance with DIN EN 1451 or KG in accordance with DIN EN 1401 with pipes and fittings of the same nominal width without the need for special transition pieces.

2.1.3 Installation underground

RAUPIANO PLUS is approved for underground installation both inside and outside the building structure.

Installation must be carried out in accordance with DIN EN 12056, DIN EN 752, DIN 1986-100 and DIN EN 1610.

2.1.4 Commercial kitchens

RAUPIANO PLUS is ideal for use as a collecting and ground pipe for drainage of greasy waste water from commercial kitchens up to the grease separator.

For grease separators at great distances, the use of pipe trace heating may be necessary. This prevents premature grease accumulation. The temperature of the pipe trace heating suitable for plastic pipes may not exceed 45 °C.

2.1.5 VACUCLEAN central vacuum cleaner system

Due to its excellent sound-insulation properties and the abrasion-resistant inner layer that is optimised for low-friction, RAUPIANO PLUS is also suitable as a pipeline system for central vacuum cleaner system.

REHAU offer the VACUCLEAN central vacuum cleaner system, which comprises of a central suction unit, pipelines, fittings, brackets and suction sockets. For more detailed information on this product, see technical information „VACUCLEAN central vacuum cleaner system“ or go to www.rehau.ae on the Internet.

2.2 Application



Fig. 2-1 RAUPIANO PLUS pipes and fittings

The sound-insulating domestic waste water system RAUPIANO PLUS is suitable for gravity drainage systems in accordance with DIN EN 12056, DIN EN 752 and DIN 1986-100 in buildings and for underground installation inside and outside the building structure and is approved by the German Institute of Building Technology (DIBt) in Berlin (ABZ-42.1-223).

The pipes, fittings and seals can be used at up to 95 °C (for brief periods). They are suitable for the drainage of chemically aggressive waste water with a pH value of 2 (acidic) to 12 (basic). Behaviour in fire corresponds to B2 normally inflammable according to DIN 4102.

The pipe connections are leak-proof up to an internal excess water pressure of 1.0 bar (10 m water column).

Pipes and fittings may not be used for:

- pipes subject to a continuous flow of more than 90 °C (for brief periods 95 °C)
- pipes carrying waste water containing petrol or benzene
- exposed pipes outdoors

If used in areas in which temperatures below -10 °C are common during installation, additional tests are required according to DIN EN 1451. RAUPIANO PLUS has passed the test and may therefore also be marked with the „ice crystal“ according to DIN EN 1451 and DIN EN 1411 and be installed in these regions.



For outlet pipes of ventilation lines, use UV-stable pipes instead of RAUPIANO PLUS.



Observe the generally applicable installation, accident-prevention and safety regulations when installing domestic waste water pipes and the notes in this technical information.

Areas of application not dealt with in this technical information (special applications) require consultation with our applications department. Please contact your REHAU sales office.

2.3 Pipe structure

Modern pipe systems are constructed with multiple layers. This allows desired pipe characteristics to be matched to the respective requirements in a targeted way.

RAUPIANO PLUS features a three-layer wall construction. This „sandwich construction“ is based on modern design principles. Each layer is of considerable importance in the overall functioning of a reliably operating pipe system. The multi-layer structure increases pipe rigidity. Technically desirable characteristics are optimised in a targeted way.

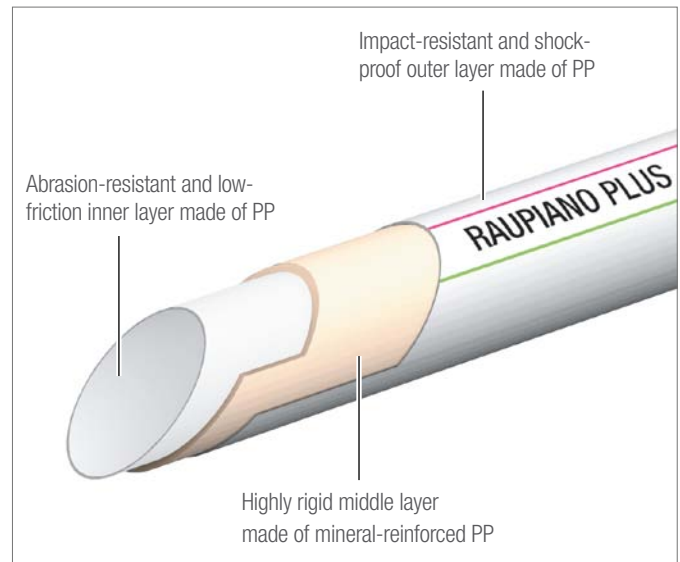

Fig. 2-2 RAUPIANO PLUS pipe structure



- RAUPIANO PLUS – robust enough for transport, storage and handling at the construction site
- Fracture resistant down to -10 °C
- Can be stored outdoors for up to 2 years (for Central Europe)
- Optimum hydraulic characteristics. Accumulation of deposits and incrustations are reliably prevented.
- Still the best in sound insulation

These ideal characteristics are achieved thanks to the three-layer structure of the pipe and the specialised adaptation of each individual layer to its respective requirement:

- High ring stiffness
- Excellent impact and cold impact strength of the outer layer
- Increased UV-resistance
- Abrasion-resistant and smooth inner layer
- Highly rigid middle layer made of mineral-reinforced PP

2.4 Fittings

The pipe system can experience local vibrations at redirections due to critical drainage conditions. This can have a negative effect on sound-related properties.

To minimise this effect and counteract negative influences, targeted mass optimisation was carried out in sound-critical areas of elbows with a nominal width of DN 90 to DN 160. This stabilises the sound behaviour, reduces sound generation and thus achieves even better noise dampening in the impact area.



Fig. 2-3 RAUPIANO PLUS elbow with reinforced impact area

2.5 Sound insulation

The sound-insulating domestic waste water system RAUPIANO PLUS guarantees quality, quiet and living comfort in an important area of building technology. In practice-oriented measurements carried out by the officially recognised Fraunhofer Institute for Building Physics in Stuttgart, Germany, RAUPIANO PLUS reached a sound-intensity level which was below the most stringent requirements of VDI guideline 4100.



- Excellent sound insulation
- High pipe rigidity (ring stiffness $> 4 \text{ kN/m}^2$ in accordance with DIN EN ISO 9969)
- Optimum hydraulics thanks to an extremely smooth and low-friction inner layer
- Increased installation-friendliness thanks to a tough outer layer
- Excellent cold impact strength (ice crystal in accordance with DIN EN 1451/1411)
- Safe to install at low temperatures
- Easy and sensible installation
 - Push-fit socket joint
 - Sealing rings installed at the factory
 - Shortened with common pipe cutters or slitting saw
- Complete pipe and fitting line
- Universal compatibility with the HT-PP system, connection to common HT and KG pipes without special adapters
- Attractive appearance in visible areas
- Sanitary white colour
- Environmentally friendly – can be recycled

2.6 System components

Pipes and fittings

- Made of mineral-reinforced RAU-PP
- Dyed white (similar to RAL 9003)
- Nominal size DN 40, 50, 75, 90, 110, 125, 160, 200
- Available in lengths from 150 mm to 3 000 mm
- Complete fitting line
 - Elbow from 15° to 87° (DN 90 to DN 125 in thicker-walled version)
 - Single branch
 - Double branch
 - Corner double branch
 - Parallel branch
 - Additional special fittings

Seals

The pipes and fittings are pre-installed with a lip sealing ring at the factory in accordance with DIN 4060 and DIN EN 681-1.

Hardness: 60 ± 5 Shore A

Material: Styrene butadiene rubber (SBR)

Fastening elements



Fig. 2-4 Patented sound dampening support bracket

- Sound dampening support bracket
- Fixing clamp
- Guiding clamp

Fire protection



The fire behaviour is in accordance with material class B2 in accordance with DIN 4102.

REHAU fireproofing collars are available for passage of the RAUPIANO PLUS pipe through fire-resistant ceilings or walls.

The national fire-protection regulations and the respective applicable codes/regulations of building practice are to be observed here.



Fig. 2-5 "compact" fireproofing collar

2.7 Form of delivery and storage

Form of delivery

- Pipes up to 500 mm and fittings included in the box
- Pipes 750 mm and longer in wooden crates

Transportation

RAUPIANO PLUS proves its robustness during transport and at the construction site thanks to its three-layer structure and impact-resistant and shock-proof outer layer. Ensure that pipes make firm contact over their entire length.

Storage

- Protect boxes from wetness during transport and storage.
- RAUPIANO PLUS and its seals can be stored outdoors for up to 2 years (Central Europe) due to its UV-stable characteristics.

We recommend:

- protecting RAUPIANO PLUS pipes and fittings from direct sunlight and soiling
 - in the box
 - by covering them with tarpaulins (ensure proper ventilation).
- Stack no more than four wood crates on top of one another.
- Ensure that the wood frames are aligned squarely when stacking.
- Store pipes in such a way that no objects are placed on top of the sockets and insertion ends and that these are not deformed.

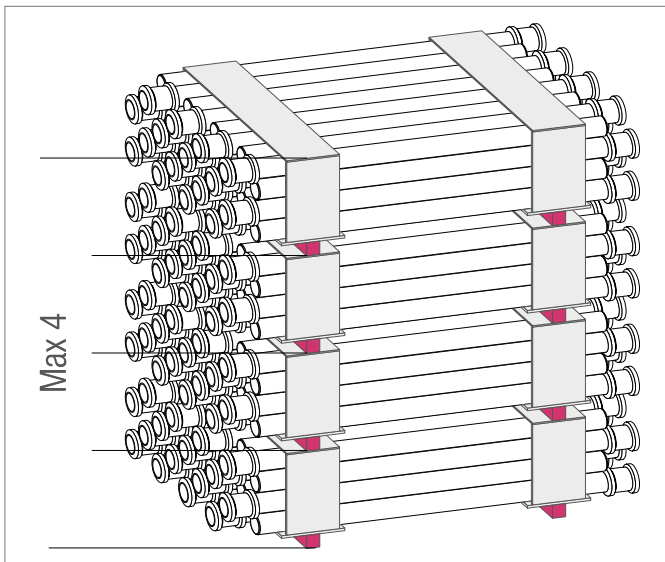

Fig. 2-6 Recommended storage of RAUPIANO PLUS

2.8 Marking

Pipes and fittings are marked with the following:

- Manufacturer's mark
- Approval number
- Mark of quality
- Ice crystal (DIN EN 1451/1411)
- Nominal width (DN)
- Year of manufacture
- Production plant
- Material
- Angle specification (with elbows and branches)

2.9 Recycling

RAUPIANO PLUS pipes and fittings are 100 % recyclable.

3 SOUND INSULATION

3.1 Sound-insulation requirements



The applicable national regulations regarding sound insulation are to be observed.

To assess the sound-insulation behaviour of RAUPIANO PLUS, the sound-insulation requirements applicable in Germany are described in the following.

There are currently two important bodies of rules for sound insulation in residential buildings:

- DIN 4109 (Sound insulation in buildings – Requirements and verifications, issued November 1989)
- VDI guideline 4100 (Sound insulation in residential buildings – Criteria for planning and assessment, issued September 1994)

DIN 4109

This standard regulates the sound insulation requirements against noise from outside of the building and adjacent units to limit the sound transmission level into the living areas. Sound insulation is required for protection against health risk due to noise.

Building drainage systems are to be planned under observance of DIN 4109. The rooms to be insulated include:

- Bedrooms
- Living rooms
- Classrooms
- Workspace (offices, treatment rooms, conference rooms etc.)

DIN 4109 does not specify any requirements for insulation against noise from within your own living areas.

A maximum noise level transmission of 30 dB(A) from outside of the building is stipulated for water installations (water supply and sewer pipe systems together).



DIN 4109 represents a minimum requirement in a public-law sense. The requirements based on this standard are no longer current, however.

VDI guideline 4100

VDI guideline 4100 represents more stringent sound-insulation requirements. It defines three sound-insulation levels and differentiates between apartments in multistorey apartment blocks, semi-detached houses and row houses and, in contrast to DIN 4109, also takes your living space into consideration (water supply and sewer pipe systems together (see Tab. 3-1)).



VDI guideline 4100 is not legally binding, but rather a guide, and therefore enjoys a great degree of recognition, not only in professional circles. Individual legal provisions of a private nature therefore allow the stipulation of these more stringent requirements.

Sound-insulation level	Apartments in multistorey apartment blocks	Apartments in semi-detached houses and row houses	Your own living area
I	30 dB(A) (purs. to DIN 4109)	30 dB(A) (purs. to DIN 4109)	30 dB(A)
II	30 dB(A)	25 dB(A)	30 dB(A)
III	25 dB(A)	20 dB(A)	30 dB(A)

Tab. 3-1 Sound-insulation requirements pursuant to VDI guideline 4100

3.2 Basics

In every area of building construction, especially the construction of multistorey apartment blocks, hospitals and convalescent homes, sound insulation plays an increasingly important role. One of the most significant sources of sound within buildings is the sanitation set-up and the accompanying domestic waste water pipe system.

Typical sources of sound include:

- Fitting noises
- Filling noises
- Draining noises
- Inlet noises
- Impact noises

An unsuitable sewer pipe system and type of bracketing are considerable contributors to disturbing noise. RAUPIANO PLUS, a system-tested, universal sound-insulating domestic waste water system, puts things right.

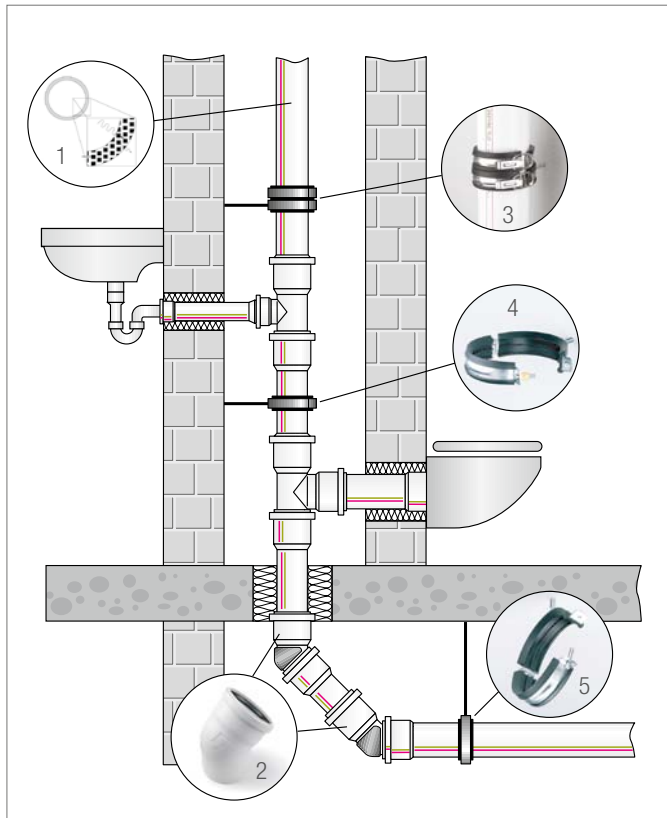

Fig. 3-1 Sound minimising
Airborne noise reduction through
 1 Special pipe and fitting materials
 2 Mass optimisation in the redirection area of fittings

Structure-borne noise minimisation through
 3 Patented sound-proof attachment
 4 Optimised guiding clamp
 5 Fixing clamp with elastomer insert

A differentiation is made between airborne noise and structure-borne noise, depending on the propagation medium.

Airborne noise

Airborne noise is present if the noises of a sound source are transferred directly through the air to people.

Structure-borne noise

With structure-borne noise, the sound transfer first occurs through a solid body. This body vibrates and passes the vibrations on to people as airborne noise.

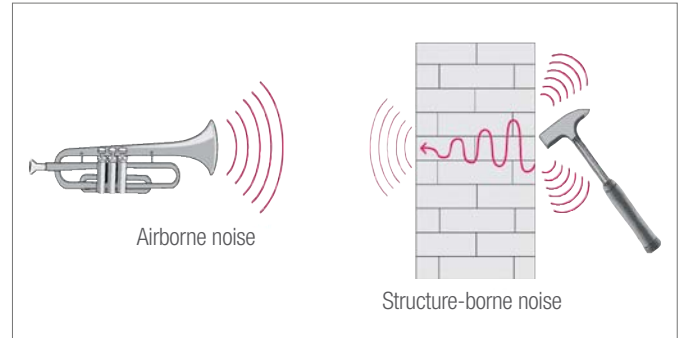

Fig. 3-2 Airborne and structure-borne noise

3.3 Sound reduction with RAUPIANO PLUS

Both structure-borne and airborne noise occurs in sewer pipe systems. The pipe wall of the sewer pipe vibrates due to currents and flow noises. The type and intensity of these pipe vibrations depend on a variety of factors, such as the mass of the pipe, the pipe material and its inner dampening.

The pipe vibrations are emitted directly from the pipe as airborne noise and are transferred as structure-borne noise via the pipe attachments to the wall fastening panel.

When developing a sound-insulating domestic waste water system, both types of sound distribution must be taken into account.

Airborne noise insulation with RAUPIANO PLUS

Airborne noise is reduced with RAUPIANO PLUS thanks to special materials, sound-dampening fillers and increased weight of the pipe system. Targeted mass optimisation in sound-sensitive areas of fitting elbows of nominal size from DN 90 to DN 160 provides further improvement at redirection points.

Structure-borne noise insulation with RAUPIANO PLUS

The transmission of structure-borne noise to the wall fastening panel is reduced with RAUPIANO PLUS thanks to a special clamp attachment:

- A supporting clamp with weak coupling to the pipe represents the connection of the pipe to the wall.
- A fastening clamp without a fixed connection to the supporting clamp keeps the pipe in position.

This extensive physical decoupling of the pipe, bracket and wall fastening panel means that the transmission of structure-borne noise is eliminated to a high degree (see Chapter 7).

Structure-borne noise bridges reduce the sound-insulation effect of every sound-insulation system.

- Avoid direct contact between pipes and the wall fastening panel.
- Avoid structure-borne noise bridges via subsequent work from other crews/ tradesmen.
- Use only RAUPIANO PLUS brackets.

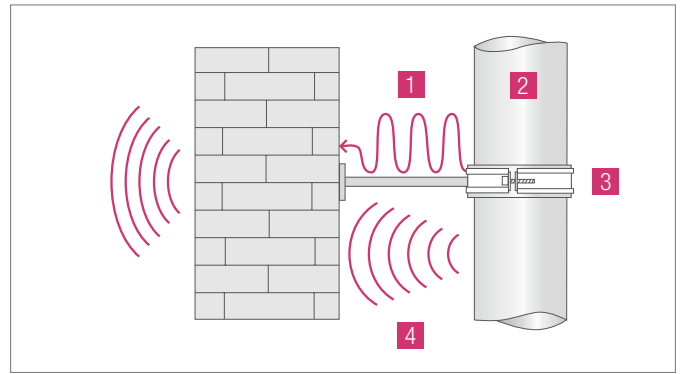

Fig. 3-3 Sound distribution with sewer pipe systems

- 1 Structure-borne noise
- 2 HT-PP pipe
- 3 Standard attachment (pipe clamp with/without rubber ply)
- 4 Airborne noise

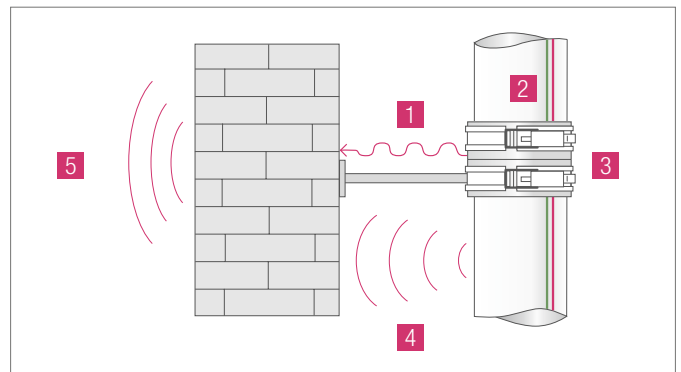

Fig. 3-4 Sound insulation with RAUPIANO PLUS

- 1 Reduction of structure-borne noise
- 2 RAUPIANO PLUS pipe with sound-dampening fillers
- 3 RAUPIANO PLUS attachment, patented sound-dampening support bracket
- 4 Reduction of airborne noise
- 5 Sound insulation in accordance with VDI guideline 4100

3.4 Laboratory testing of the sound-insulation behaviour

To determine the effectiveness of the sound insulation, the domestic waste water system RAUPIANO PLUS was assessed by the officially recognised Fraunhofer Institute for Building Physics (IBP) in Stuttgart, Germany in accordance with DIN EN 14366 "Laboratory measurement of noise from waste water installations". Sound-related examinations were carried out within the context of a standardised installation structure mimicking a real situation. Different volume flows representing a multi-person household in a realistic way form the basis. It was determined here that the sound level applicable as the permissible minimum standard of 30 dB(A) pursuant to DIN 4109 is undershot by far. It showed that RAUPIANO PLUS achieved values under the maximum limit (Sound-insulation level III/Apartments in semi-detached houses and row houses, water supply and sewer pipe systems together) of the much more stringent VDI guideline 4100.

The schematic layout of the installation test set-up of the IBP is presented graphically (see Fig. 3-5). The system is loaded with a volume flow of 1.0 / 2.0 and 4.0 L/sec. (4 L/sec. corresponds to simultaneous flushing of two 6 L toilets). The results of the examination in comparison to the common HT pipe show a clearly lower sound level behind the wall fastening panel (surface weight of 220 kg/m², wall thickness 115 mm, plus plaster). This wall fastening panel corresponds to the lightest single-layer wall pursuant to DIN 4109 to which domestic waste water pipes may be attached. If installation to heavier walls will occur, the sound level is reduced even further.

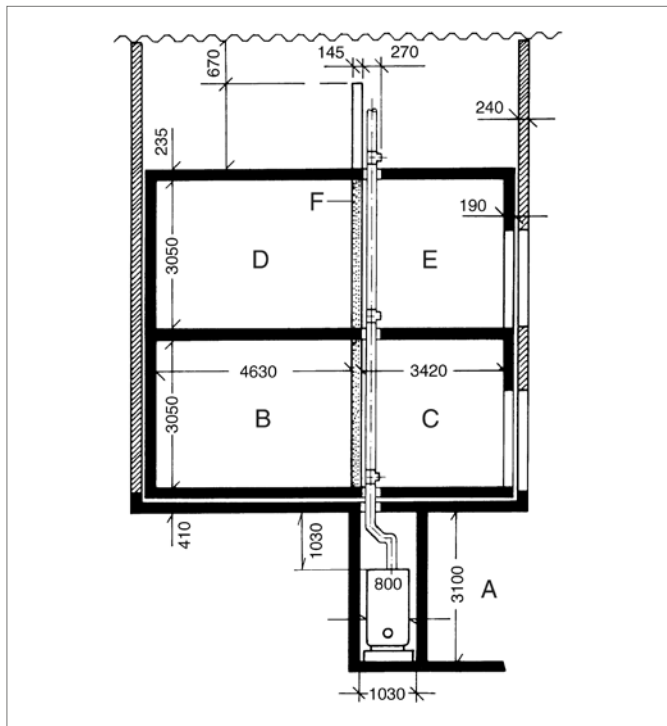

Fig. 3-5 Installation set-up of the Fraunhofer Institute for Building Physics (all measurements in mm)

- A Cellar
- B Basement, rear
- C Basement, front
- D Ground floor, rear
- E Ground floor, front
- F Wall fastening panel (surface weight: 220 kg/m²)

3.5 Measurement results

Here is the impressive documentation of the excellent sound-insulation properties of the RAUPIANO PLUS domestic waste water system.

When the information regarding pipe support using sound-proof brackets provided in our technical documentation is observed and information provided in the applicable standards and rules of the technology is complied with, planning and proposal work can be carried out in accordance with VDI guideline 4100. This guideline specifies, among other things, a sound level up to 20 dB(A) for apartments in semi-detached and terraced houses or 25 dB(A) for apartments in multistorey apartment blocks.

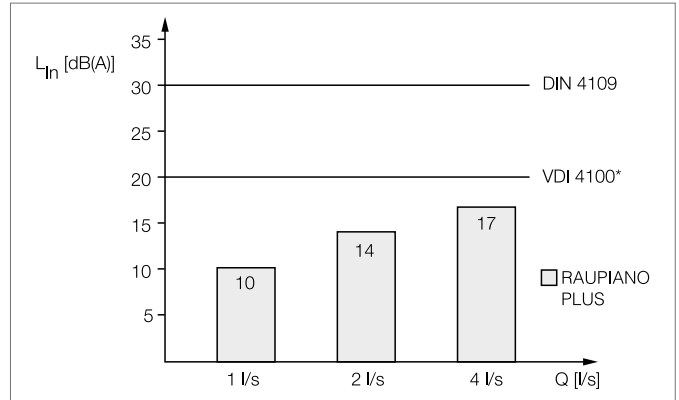

Fig. 3-6 Measurement results with a sound-dampening support bracket in the basement behind the wall fastening panel (source: Fraunhofer Institute for Building Physics, Stuttgart, Germany, Test Report P-BA 6/2006)

L_{in} Installation sound level

Q Volume flow

*) Maximum requirement of VDI guideline 4100 (Sound-insulation level III/ Apartments in semi-detached and row houses, water supply and sewer pipe systems together)

If there is no stringent sound-insulation requirement, the sound-dampening support bracket does not need to be used.

When using a standard clamp (e.g. BIFIX 1301), the RAUPIANO PLUS sound-insulation properties are well below the requirements of DIN 4109. The sound-insulation properties ensure a high degree of sound insulation in owner-occupied single-family houses as well.

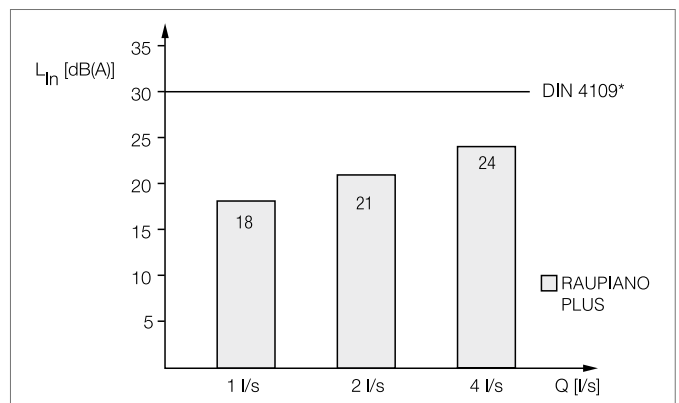

Fig. 3-7 Measurement results with standard clamp in the basement behind the wall fastening panel (source: Fraunhofer Institute for Building Physics, Stuttgart, Germany, Test Report P-BA 176/2006)

L_{in} Installation sound level

Q Volume flow

*) Maximum requirement of DIN 4109 (Sound insulation in buildings, water supply and sewer pipe systems together)

4 FIRE PROTECTION



The behaviour of RAUPIANO PLUS in a fire corresponds to material class B2 (normally inflammable) in accordance with DIN 4102, Part 1.

4.1 Fire-protection requirements

With regard to drainage pipes, fire protection measurements may be necessary if pipes penetrate through fire-rated building elements in a building.



With regard to fire protection, the applicable national regulations and the valid codes/regulations of building practice are to be observed.

4.2 Fireproofing collars

For fire protection with ceiling and wall passages using RAUPIANO PLUS waste pipes, the following fireproofing collars are available:

- Fireproofing collar system REHAU PLUS
 - Installation in a wall or ceiling
 - Installation on a wall or ceiling
- REHAU "compact" fireproofing collar system
 - Installation on a wall or ceiling
- REHAU angled fireproofing collar system
 - Installation on a ceiling for angled penetrations

When using fireproofing collars in the ceiling, they can be assembled immediately or subsequently, depending on their type.



Wall penetrations require two collars (on both sides of wall).

To use REHAU angled fireproofing collar system on penetration of drainage pipe through concrete ceiling at an angle, a minimum ceiling distance of 50 mm is required for the horizontal drainage pipe running below the concrete ceiling.



When planning and assembling the fireproofing collars, the requirements of the general building construction approval and the specifications of the assembly instructions must be observed.



When using the fireproofing collars, the applicable national regulations must be observed.

We recommend always getting approval from the responsible construction authority for compliance with the respective requirements.

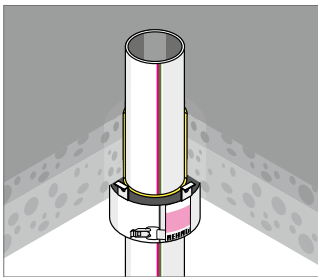

Fig. 4-1 Installation of fireproofing collar in ceiling

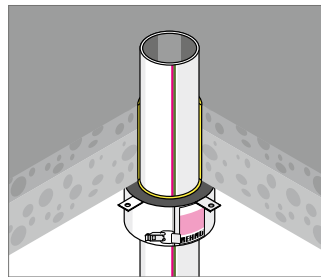

Fig. 4-2 Installation of fireproofing collar on ceiling

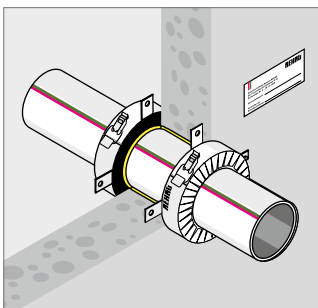

Fig. 4-3 Installation of fireproofing collar on wall

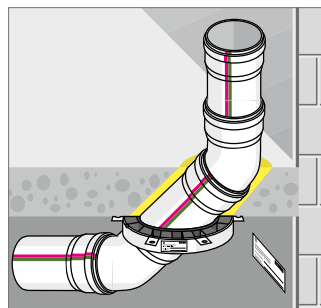

Fig. 4-4 Angled fireproofing collar (only for installation on ceiling)

5 DESIGN AND PLANNING

5.1 Measurement basics

The following standards apply for the planning and installation of RAUPIANO PLUS

- DIN 1986-100 Drainage systems on private ground
- DIN EN 12056 Gravity drainage systems inside buildings
- DIN EN 752 Drainage systems outside buildings

The goal is to ensure intended functioning of the universal domestic waste water system RAUPIANO PLUS, i.e.

- Extraction or leaking of sealing water must be prevented
- Ventilation of the drainage system must be ensured
- Nominal widths larger than those calculated are not to be used
- Sewage must drain with little noise
- Anaerobic digestion is to be prevented
- Gas emissions are to be lead out without harmful effects via the main ventilation system

A standard-compliant design is ensured when our planning software RAUCAD EN 12056 is used.

5.2 Assembly times

The assembly times are approximate. They include:

- Testing and preparing plans and materials at the construction site
- Reading plans
- Drawing up measurements
- Preparing pipes and fittings for installation and assembling
- Creating connections

The working times specified are for one person and are given in individual minutes. They are oriented toward assembly times for sound-insulating domestic waste water pipes with a sleeve connection of the German Plumbing, Sanitation and Heating Guild in Munich.

	Pipe (running m)	Adapter and fitting pc.	Attachment pc.
DN 40	15	5	7
DN 50	15	5	7
DN 75	19	7	7
DN 110	22	9	7
DN 125	26	12	7
DN 160	33	14	12

Tab. 5-1 Assembly times in individual minutes

Source: Assembly times of the German Plumbing, Sanitation and Heating Guild of Munich, 6th fully revised and expanded edition, 2005

5.3 Specification

Domestic waste water system comprised of hot water-resistant, sound-insulating RAUPIANO PLUS pipes and fittings from DN 40 to DN 200 with push-fit sockets made of mineral-reinforced PP and accessories for installation as sewer pipes inside and outside buildings in accordance with DIN EN 12056, DIN EN 752 and DIN 1986-100. The dimensions correspond with DIN EN 1451-1. The sound-insulating properties of the system, which are oriented toward the requirements of VDI guideline 4100 (Sound insulation in residential buildings – Criteria for planning and assessment) or DIN 4109 (Sound insulation in buildings), are verified by Test Report No. P-BA 6/2006 (with sound-damping support bracket) or P-BA 176/2006 (with standard clamp BIFIX 1301) from the Fraunhofer Institute for Building Physics, Stuttgart, Germany.

Standards

DIN EN 12056:

Gravity drainage systems inside buildings;

Part 1: General and performance requirements

Part 2: Sanitary pipework, layout and calculation

Part 3: Roof drainage, layout and calculation

Part 4: Sewerage lifting plants, layout and calculation

Part 5: Installation and testing, instructions for operation, maintenance

DIN 1986-100:

Drainage systems on private ground;

Part 100: Additional requirements for DIN EN 752 and DIN EN 12056

DIN 1986-3:

Drainage systems on private ground;

Part 3: Regulations on operation and maintenance

DIN 1986-4:

Drainage systems on private ground;

Part 4: Areas of use of sewer pipes and fittings made of various materials

DIN 1986-30:

Drainage systems on private ground;

Part 30: Service

DIN EN 752:

Drainage systems outside buildings

DIN EN 1451-1:

Plastic piping systems for soil and waste discharge (low and high temperature) within the building structure – Polypropylene (PP);

Part 1: Specifications for pipes, fittings and the pipeline systems

Technical information domestic waste water system RAUPIANO PLUS and VACUCLEAN central vacuum cleaner system and other included standards, directives and regulations.

Approvals, quality assurance

General building construction approval Z-42.1-223 of the German Institute for Building Technology in Berlin, Germany.

In addition to continuous self-monitoring, contractually regulated quality monitoring (external monitoring) is carried out in accordance with the building construction permit by the Süddeutsche Kunststoff-Zentrum (SKZ) Germany. The pipes and fittings are labelled with the quality mark of the external monitoring location and approval number Z-42.1-223.

Installation

In accordance with installation regulations in this technical information in compliance with the specifications of DIN EN 12056, DIN 1986, DIN EN 752 and VDI-guideline 4100 or DIN 4109.

Quality assurance

REHAU are, among other things, certified in house and building technology in accordance with DIN ISO 9001. This certification applies for both the production and technical/commercial departments.

Tender texts

Tender texts in the PDF, GAEB, LLV and Word formats are available for download on the Internet at www.rehau.ae.

6 ASSEMBLY OF RAUPIANO PLUS

6.1 Shortening and tapering pipes



Fittings may not be shortened.

1. If necessary, shorten pipes with common pipe cutters or a fine-tooth saw.
2. Make cut at a 90° angle from the pipe axis.
3. For connections to push-fit socket pipe systems, taper the pipe ends with a tapering tool or a coarse file at an angle of approx. 15°.
4. De-burr and break cut edges.



Danger of damage to property!

At low temperatures, the mineral-reinforced pipe material RAU-PP becomes brittle and thus more sensitive to impacts, like every other material.

The optimised material consistency of RAUPIANO PLUS is characterised by excellent cold impact strength. RAUPIANO PLUS is marked with the ice crystal in accordance with DIN EN 1451/1411 to indicate this.

6.2 Joining fittings and pipes

1. Clean dirt from sealing ring, sleeve interior and spigot end.
2. Coat spigot end with REHAU lubricant and slide into the sleeve until it stops.
3. Mark inserted spigot end in this position at the sleeve edge with a pencil, pen, etc.
4. With longer pipes (> 500 mm), pull the spigot end out an additional 10 mm from the sleeve to create an expansion joint for heat-related expansion.
5. With short pipes (≤ 500 mm) and fittings, insert the spigot ends fully into the sleeves.

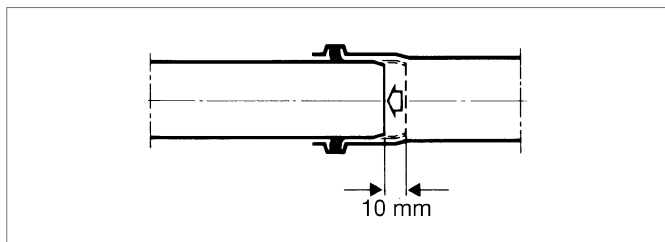

Fig. 6-1 Pulling out spigot ends for expansion joints



By pulling out the spigot ends from the sleeves, the changes in length of the pipe caused by temperature fluctuations are absorbed in the push-fit sockets. Each RAUPIANO PLUS pipe sleeve can accept the changes in length of a waste pipe up to 3 m in length (coefficient of linear expansion in accordance with DIN 53752 averages 0.09 mm/(m-K) at 0 °C to 70 °C).

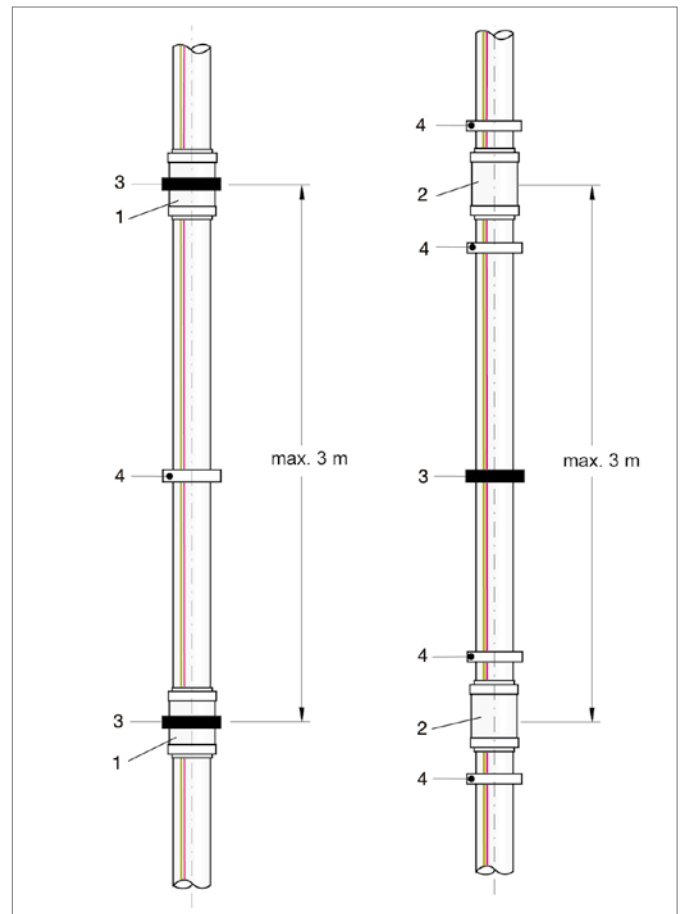

Fig. 6-2 Using double sockets and sleeve couplers

- | | |
|------------------|-----------------|
| 1 Double socket | 3 Fixing clamp |
| 2 Sleeve coupler | 4 Guiding clamp |

6.3 Handling cut lengths and remaining lengths

Cut lengths and remaining lengths (pipes with smooth ends) can be joined with double sockets and sleeve couplers up to a maximum pipe length of 3 m. Ensure that sufficient expansion joints are present in the pipe sleeves here as well.

6.4 Installation of additional fittings

The installation of additional fittings in an existing pipeline is possible with sleeve couplers:

1. Cut out a sufficiently long section of pipe from the pipeline:
fitting length + 2 x pipe outer diameter
2. De-burr pipe ends.
3. Slide sleeve coupler all the way onto one end of the pipe.
4. Slide fitting onto the other end of the pipe.
5. Fit adapter into the remaining space of the pipe and de-burr.
6. Slide second sleeve coupler all the way onto the adapter.
7. Insert adapter and close both gaps by sliding the sleeve couplers.
Use REHAU lubricant liberally here.

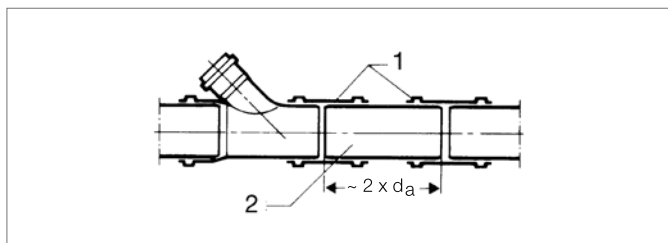

Fig. 6-3 Installing fitting

- 1 Sleeve coupler d_a Pipe outer diameter
2 Adapter

6.5 Connecting drain fitting

There are three options for connecting drain fittings (e.g. air traps) to RAUPIANO PLUS waste pipes or fittings:

- RAUPIANO PLUS connection piece
- RAUPIANO PLUS siphon angle
- RAUPIANO PLUS fitting with beaded rubber nipple

RAUPIANO PLUS connection piece

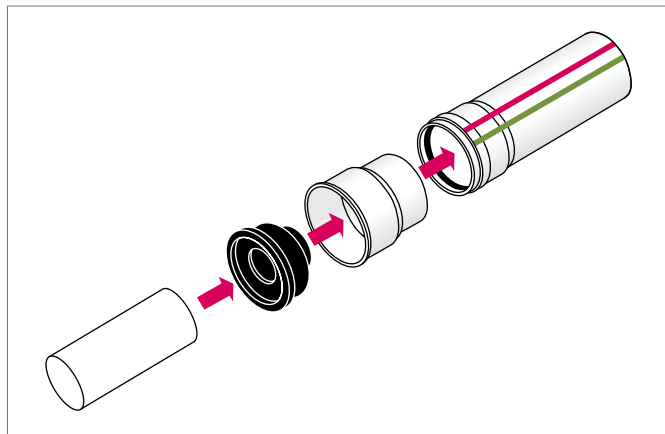

Fig. 6-4 RAUPIANO PLUS connection piece with rubber nipple

1. Insert rubber nipple in the socket of the connection piece.
2. Apply REHAU lubricant on the sealing lips of the rubber nipple.
3. Insert nozzle of the drain fitting into the rubber nipple.

RAUPIANO PLUS siphon angle

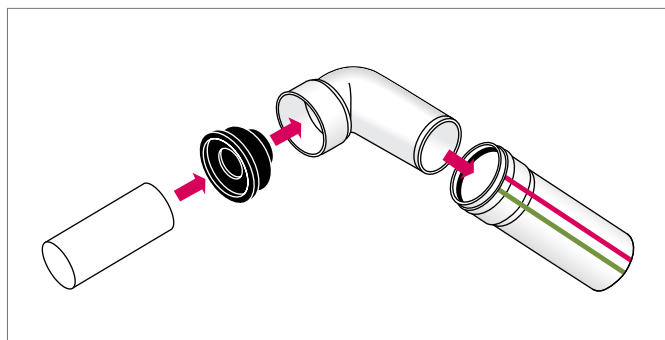

Fig. 6-5 RAUPIANO PLUS siphon angle with rubber nipple

1. Insert rubber nipple in the socket of the siphon angle.
2. Apply REHAU lubricant on the sealing lips of the rubber nipple.
3. Insert nozzle of the drain fitting into the rubber nipple.

RAUPIANO PLUS fitting with beaded rubber nipple

1. Remove the installed sealing rubber from pipe or fitting socket.
2. Insert rubber nipple with bead into the fitting socket.
3. Insert nozzle of the drain fitting into the rubber nipple.

6.6 Connection pieces for cast iron pipes/other materials

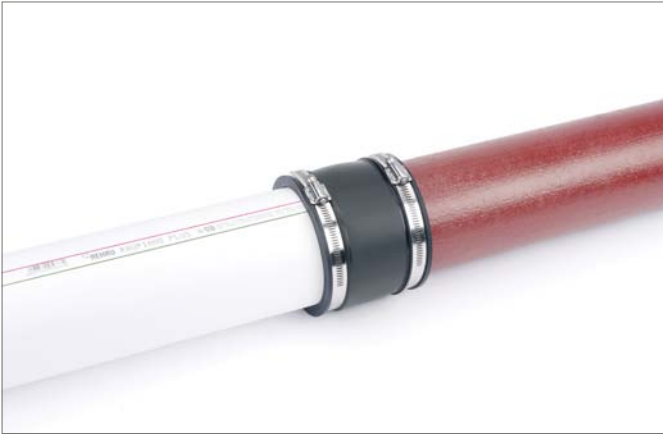

Fig. 6-6 Connection piece for same outer diameters DN110/DN110



Fig. 6-7 Connection piece for different outer diameters DN110/DN 90

For transition from RAUPIANO PLUS pipes to Cast Iron pipes or other materials for drainage systems, rubber sleeve adaptors can be used. These rubber sleeves come with rubber seal that is attached to the pipe ends and two stainless-steel worm-gear clamps. These rubber sleeve adaptors can be used in new construction or renovation works.

Below are the properties of the rubber sleeve adaptor.

Material	Rubber
Tightening device	Stainless-steel worm-gear clamps
Recommended tightening torque	3 Nm
Pressure resistance	1 bar
Chemical resistance	pH 2 – 12

Tab. 6-1 Properties of rubber sleeve adaptor

Installation steps:

4. Insert RAUPIANO PLUS pipe end into one end of the rubber sleeve adaptor.
5. Insert Cast Iron / other material pipe end into the other end of the rubber sleeve adaptor.
6. Tighten the worm-gear clamps on both ends of the rubber sleeve adaptor without exceeding the maximum tightening torque.

The rubber sleeve adaptor can be installed on most Cast Iron and other materials pipe sizes, the table below specifies the suitable dimensions of Cast Iron or other pipe materials.

Article No.	Description	RAUPIANO PLUS OD Size	OD of other pipe material
125024-001	50/53 – 63	50	53 – 63
125034-001	75/75 – 89	75	75 – 89
123904-001	110/90	110	75 – 89
123914-001	110/110	110	100 – 115

Tab. 6-2 Suitable sizes for rubber sleeve adaptor.

6.7 Adapting to PVC system

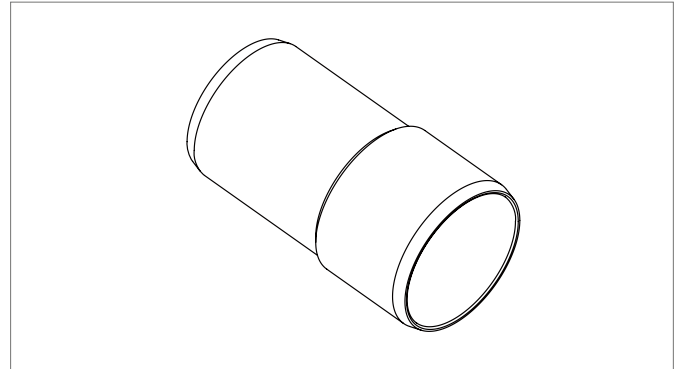

Fig. 6-8 Adaptor fitting from RAUPIANO PLUS to PVC system

If it is necessary to adapt to PVC system, which complies to AS/NZS 1260 or other standards with the same pipe outer diameter, the simple adaptor from RAUPIANO PLUS to PVC system is available.

Installation steps:

7. Apply primer and solvent cement on the correct part of the adaptor.
8. Insert the solvent-cemented portion into a female socket of PVC fitting.
9. Apply REHAU lubricant to the other portion of the adaptor and insert it to RAUPIANO PLUS socket.

These adaptors are made of PVC and available for the following sizes:

PVC adaptor	From		To	
	RAUPIANO PLUS	OD (mm)	PVC system	OD (mm)
DN 40/43	DN 40	40	DN 40	43
DN 50/56	DN 50	50	DN 50	56
DN 75/69	DN 75	75	DN 65	69
DN 90/82	DN 90	90	DN 80	82

Tab. 6-3 Available adaptor sizes from RAUPIANO PLUS to PVC system

6.8 Flexible connection to roof vent



Fig. 6-9 Flexible connection to roof vent

The flexible connection enables a transition from roof vents to RAUPIANO PLUS ventilation lines of a drainage system.



- Avoids extensive work on fittings
- Reduces assembly time

The flexible combination connection made of polypropylene is ideal for connecting RAUPIANO PLUS pipes with the following nominal widths:

- DN 75
- DN 90
- DN 110

6.9 Cleaning the waste pipe system



Fig. 6-10 RAUPIANO PLUS cleaning pipe

Installing cleaning pipes enables mechanical cleaning of the waste pipe system.

RAUPIANO PLUS access pipe is supplied with insert to ensure flushing surface for smooth and uninterrupted water flow.

Tighten the screw cap with the rubber seal inserted after assembling the cleaning pipe.



Do not use sharp cleaning devices for mechanical cleaning.

6.10 Socket plug



Fig. 6-11 RAUPIANO PLUS socket plug.

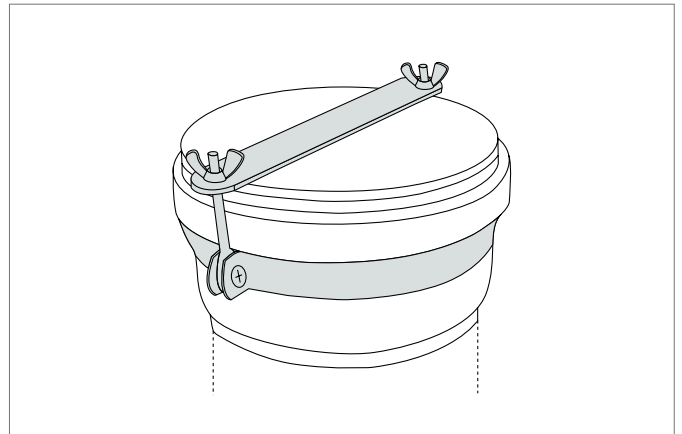

Fig. 6-12 RAUPIANO PLUS securing clip.

The socket plug can be used to plug-off the pipe ends if they are not in use. The socket plug is to be used together with the securing clip to ensure a safe and tight jointing.

6.11 P-traps

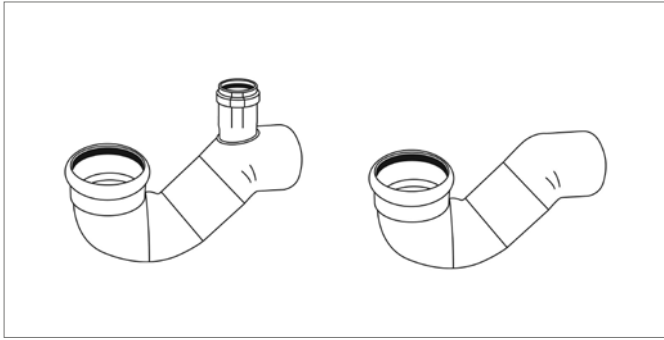

Fig. 6-13 RAUPIANO PLUS P-trap with and without venting.

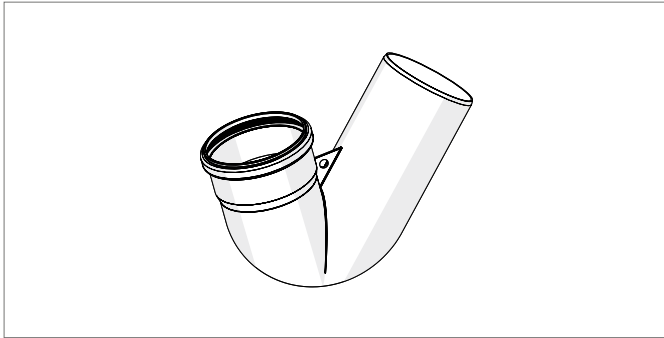

Fig. 6-14 RAUPIANO PLUS P-trap siphon

RAUPIANO PLUS P-traps provides 50 mm water seal to prevent foul odour from coming out of the drainage lines. REHAU offers three types of P-traps:

- DN 110 P-trap with venting line
- DN 110 P-trap without venting line
- DN 110 P-trap siphon, to be used together with DN 110 bend (45°)

When installing this P-trap, it is important to install the pipe support properly to ensure safe operation of the drainage system.



The P-trap siphon can be supported by attaching a hook into the built-in hole.

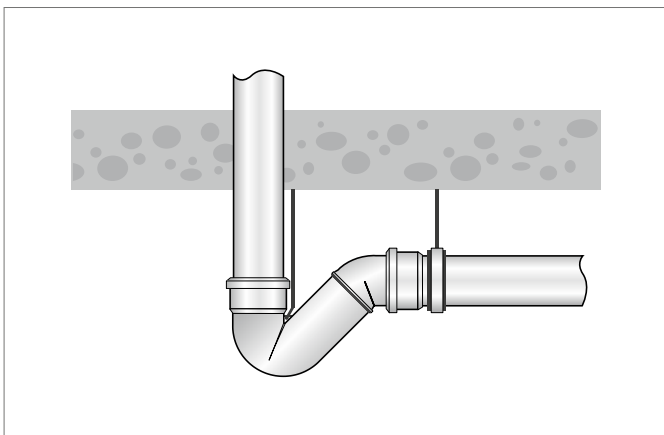

Fig. 6-15 RAUPIANO PLUS P-trap size DN 110 supported with clamp and hook

6.12 Floor trap

RAUPIANO PLUS floor trap provides not only water sealing column to prevent foul odour from coming out of the grey water line but also allow more connections from other grey water fixtures.

The floor trap consists of:

- 1 inlet of DN 110 for floor drain
- 3 inlets of DN 50 for connection from washing basin, shower or bath tube, etc.
- 1 outlet of DN 75
- Removable baffle for easy cleaning

It is important that the floor trap is properly supported to ensure safety during installation and operation. The support brackets can be installed on the horizontal pipes connected to the inlets and outlets of the floor trap.



Fig. 6-16 RAUPIANO PLUS floor trap with removable baffle

6.13 Installing pipes in installation shafts

The RAUPIANO PLUS waste pipes and fittings can be installed in installation shafts without additional structure-borne noise insulation. Heating and condensation-water insulations are only required in special cases (e.g. inlying roof drainage).

Construct wall and ceiling breakthroughs with common moisture-protected structure-borne noise insulations to acoustically decouple the pipelines.

6.14 Installing pipes in masonry



Observe the applicable national regulations for recesses and slots in the masonry.

- Make wall slots in such a way that the pipeline can be laid without being tensioned.
- Avoid sound bridges between the masonry and the pipe.

If the pipes will be plastered in directly without using a plaster board (e.g. brick rabbit, expanded metal baffle) or cladding:

- Cover pipes and fittings on all sides with flexible materials such as mineral or glass wool or commercial insulation tubes beforehand.
- If using plaster boards, close the slot beforehand with mineral wool, for example. This prevents sound bridges from forming between the pipe and masonry when applying the plaster.
- Protect pipes and fittings from the effects of high temperatures with appropriate measures for heating insulation at points at which temperatures over 90 °C are reached due to external influences.

6.15 Installing pipes in concrete



If setting in concrete, we recommend decoupling the pipelines from the main structure by using common moisture-protected structure-borne noise insulations with a thickness greater than 4 mm. A limitation of the sound-insulation effectiveness can be expected, however.

- Attach pipe components in such a way that a change in position during concrete application is prevented.
- Ensure sufficient expansion joints when installing the pipe.
- Seal off sleeve gap with adhesive strips to prevent the penetration of concrete.
- Seal off pipe openings before concrete application.



Damage to the pipelines!

- Avoid placing the weight of the concrete on the pipelines by making provisions for dissipating the load, e.g. by using:
 - Spacers in the case of reinforcing steels
 - Carrying boxes
 - Brackets
- Avoid walking on the pipes during concrete application.

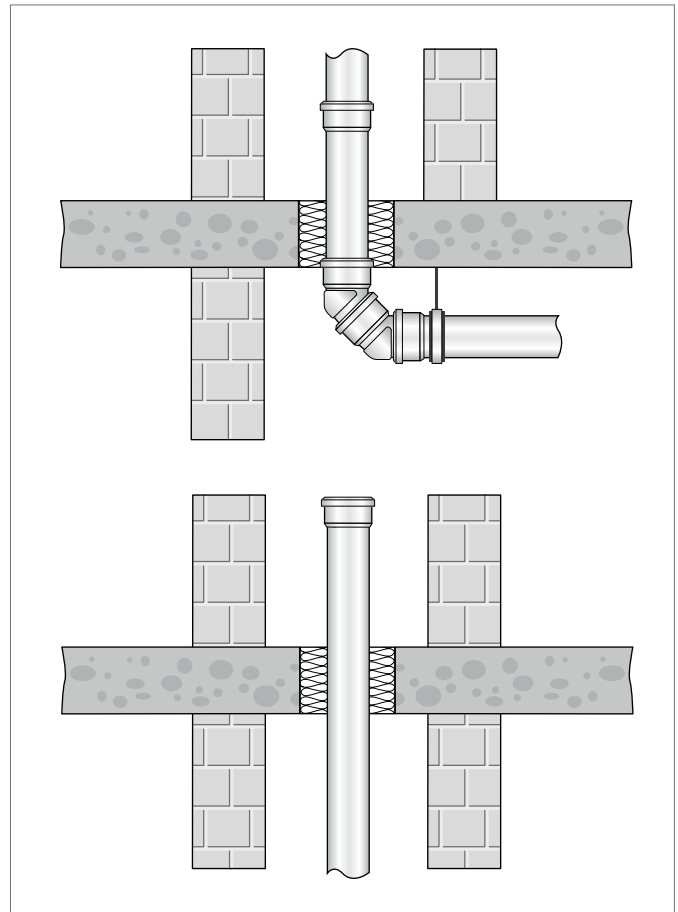

Fig. 6-17 Recommended ceiling penetration practices

6.16 Installation above suspended ceilings

Installation above suspended ceilings may require additional measures due to the special installation situation so as to ensure a high degree of sound insulation.

The insulation can be in the form of acoustically active pipe shells (e.g. combination of open-pore foam or mineral fibre mats with a thickness of approx. 30 mm and special heavy foils).

Since complex ceiling systems are usually the case, the installation instructions from the ceiling manufacturer regarding sound insulation are to be obtained.

6.17 Ceiling penetrations

Ceiling penetrations must be constructed to be moisture-proof and sound-insulating.

If mastic asphalt is to be applied to the floor:

Protect exposed pipeline components with ceiling liner, protective sleeves or by winding them with heat-insulating materials.

6.18 Installation as stormwater piping

There is a risk of condensation formation on the pipes installed as stormwater piping within the building.

Condensation water appears when the temperature of the pipe walls drops below the dew point temperature of the ambient air due to cold rain water, for example. Humidity from the ambient air then condenses on the pipe surface.

For this reason, all pipelines in the building on which condensation water could form are to be provided with diffusion-proof insulation material. Insulation of the collecting pipes in the cellar can be dispensed with if there is no risk of dew formation. In general, this is the case with exposed stormwater piping in unheated cellars if temperature equalisation occurs.

Condensation-water insulation materials

Closed-cell materials with high water vapour diffusion resistance are recommended for use as condensation-water insulation. If open-cell or fibrous insulation materials are used, they must have an impermeable outer layer that is firmly attached to the insulation material.

1. Close off all impact, groove, cut and end points of the insulation with a permanent seal.
2. Cut out insulation in the bracket area.
3. Pull insulation material over the bracketed section and permanently seal it to the neighbouring insulation material with adhesive.

Fixing of stormwater piping

To prevent the pipelines from sliding apart, a security clamp is to be attached to the pipe directly below the supporting clamp.

7 ATTACHMENT OF RAUPIANO PLUS

To achieve optimum sound insulation, use only RAUPIANO PLUS pipe brackets during assembly.
RAUPIANO PLUS waste water pipes must be installed tension-free.

7.1 Support bracket for vertical stack

The patented sound-dampening support bracket consists of a supporting clamp and a fastening clamp. In general, one sound-dampening support bracket per storey is sufficient.

1. Fit fastening clamp around the pipe and close it.
2. Assemble supporting clamp on masonry.

3. Open supporting clamp, insert pipe with fastening clamp and close supporting clamp.



Fig. 7-1 Supporting clamp assembled, opened



A spacer is attached at the closure of the support clamp to prevent the clamp being closed completely. This ensures minimum transmission of structure-borne noise to the wall.



Fig. 7-2 Closing supporting clamp

After installation, the fastening clamp fully lies on the supporting clamp. This achieves optimum sound decoupling.



Fig. 7-3 Fully installed support bracket

7.2 Fixing plan for vertical stack

A plan for effective bracketing of a sound-insulating stack with RAUPIANO PLUS is displayed graphically (see Fig. 7-4).



Every site is different; the installation practice described below might not be applicable all the time.

Transition to the collecting pipe (commonly at basement level)

1. Create a flow redirection from vertical stack into the collecting pipe by installing two 45° bends together with a short pipe in between (RAUPIANO PLUS pipe 200 mm).
2. To minimise the distance from the ceiling to collecting pipe, embed the socket of the top 45° bend (upper) in the ceiling area.
3. Use a fire collar if necessary.

Storey above the collecting pipe (from bottom to top)

1. Install RAUPIANO PLUS pipe just above the first 45° bend.
2. Install a branch after the vertical pipe.
3. Attach sound-dampening bracket directly below the socket of the vertical pipe.
4. Install a guiding bracket below the sound-dampening bracket with a distance of approximately 2/3 of the vertical pipe.



- Although it is a good practice to install the sound-dampening bracket directly below the pipe socket, it is not necessary to do so.
- The guiding bracket permits free longitudinal movement of the RAUPIANO PLUS drainage pipe.

Following above storeys (from bottom to top)

1. Install another RAUPIANO PLUS pipe after the branch of the lower storey to penetrate the slab, use fire collar if necessary.
2. Install a branch after the vertical pipe.
3. Attach sound-dampening bracket directly below the socket of the vertical pipe.
4. Install a guiding bracket below the sound-dampening bracket with a distance of approximately 2/3 of the vertical pipe.



If there are short pipes (≤ 500 mm) installed within the vertical stack pipe, no additional bracketing is necessary.

Additional securing bracket

To prevent the vertical stack from sliding apart, additional security brackets should be installed directly below the sound-dampening bracket:

- For single dwellings, only on the first storey.
- For multi-storey apartment buildings, on every third storey.

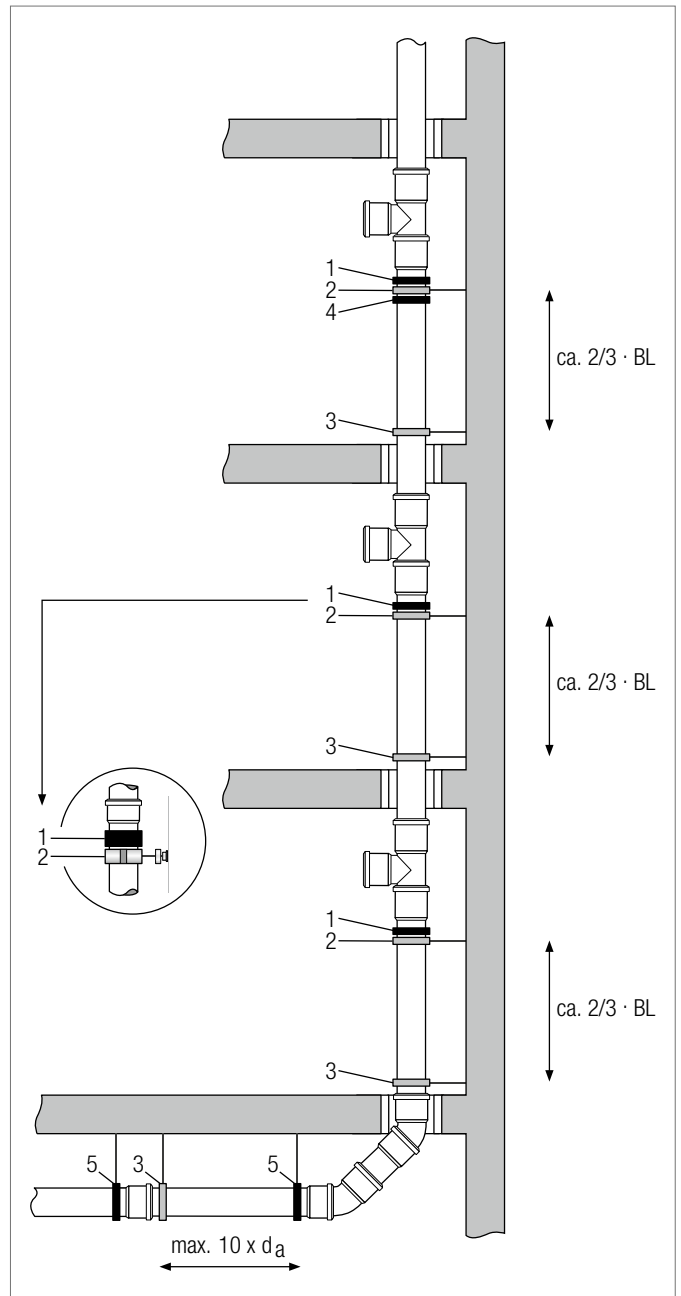

Fig. 7-4 Installation plan for vertical stack

- 1 Fastening clamp (upper part of sound-dampening bracket)
 - 2 Supporting clamp (bottom part of sound-dampening bracket)
 - 3 Guiding bracket
 - 4 Fixing/security bracket
 - 5 Fixing/security bracket
- BL Pipe length
 d_a Pipe outer diameter

7.3 Bracketing plan for horizontal pipes

A plan for effective bracketing of a horizontal sound-insulating pipe with RAUPIANO PLUS is displayed graphically (see Fig. 7-5).



Sound-dampening support brackets are not necessary for a horizontal pipe.

- For short horizontal pipes (length $\leq 10 \times$ pipe outer diameter), assemble fixing clamp directly next to the pipe socket.
- For longer horizontal pipes (length $> 10 \times$ pipe outer diameter), assemble additional guiding clamps:
- The distance between the fixing clamp and the guiding clamps may not exceed ten times the pipe outer diameter d_a (see Fig. 7-5):
Spacing $\leq 10 \times d_a$.

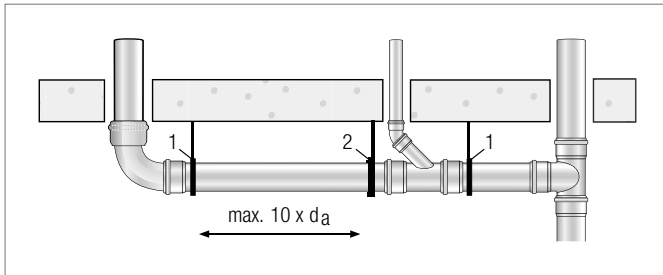

Fig. 7-5 Installation plan for horizontal pipeline

- 1 Fixing bracket
- 2 Guiding bracket
- d_a Pipe outer diameter

7.4 Short pipes and fittings

If pipe sections with fittings or short pipes are formed:

- Prevent the pipe components from sliding apart with fixing brackets.
- Secure socket plug from being pushed out by installing securing clip.

8 LAYING UNDERGROUND

RAUPIANO PLUS is ideal for installation in the ground. Installation is permissible both inside and outside the building structure. The installation is to be carried out in accordance with static requirements.

Other applicable standards/test certificates

The following standards, as well as the standards cited in the Appendix, particularly DIN EN 1610, are to be observed during pipe installation. This standard describes the installation and testing of waste water pipes and channels that are usually laid in the ground and operated under free-flow conditions.

- DIN EN 1610
- DIN EN 12056
- DIN EN 752
- DIN 1986
- General building inspectorate approval Z-42.1-223
- German Association for Water, Waste Water and Waste rules, sewage worksheet A 127

8.1 General

Generally applicable pipeline construction rules are to be followed. Careful and professional handling of the pipes and fittings during transport, storage and installation must be ensured.

Only professionals with experience in installing plastic pipes should commission the pipelines installation.



Observe the following:

- Accident prevention regulations of the employers' liability insurance
- Road traffic regulations
- Any special project-dependent regulations
- Applicable requirements contained in the regulations or technical regulations

8.2 Pipe trench

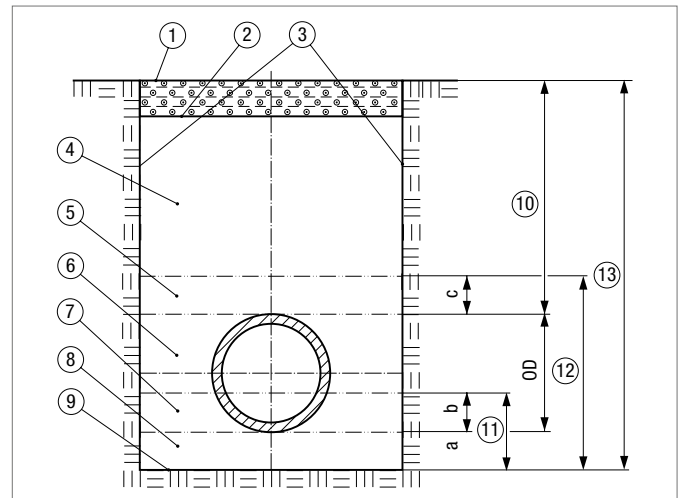

Fig. 8-1 Schematic structure of pipe trenches

- | | |
|--|---|
| 1 Surface | 10 Covering height |
| 2 Bottom edge of street or sliding construction (if present) | 11 Thick bedding or sliding construction (if present) |
| 3 Trench walls | 12 Thick embedment |
| 4 Main filling | 13 Trench depth |
| 5 Cover b | a Thick lower intermediate bedding layer |
| 6 Side filling | b Thick top bedding layer |
| 7 Top bedding layer | c Thick cover |
| 8 Bottom bedding layer | OD Outer diameter pipe |
| 9 Trench bottom | |

Pipe trenches must comply with DIN EN 1610. Note:

- Ensure the structural integrity of the trench either via suitable shoring (joists) or by scarping or other suitable measures.
- Prepare trench bottom according to the required gradient.
- Make suitable recesses in the trench bedding layer at the pipe connection points or in the trench bottom so that the entire length of the pipe makes contact.
- Ensure a consistently lying level of the pipelines.
- Protect trench bottom from the effects of frost.
- Do not use frozen material above or below the pipelines.
- Remove trench shoring materials according to the static calculations so that the pipeline is neither damaged nor repositioned.

8.3 Embedment

The embedment is the filling material around RAUPIANO PLUS pipe.

It consists of:

- Pipe bedding
- Side filling
- Cover/backfill



Ensure that the embedment is created carefully, as it is the main determining factor in the supportive capacity of the pipe.

The embedment is to be created in accordance with the static calculation based on the planning documentation. The supportive capacity, structural integrity or position of the embedment may not be changed by subsequent events, such as ground water movement or removal of the shoring material. In these cases, additional safety measures are required to prevent repositioning/shifting of the filling material.

8.3.1 Embedment materials

The embedment materials must be according to the planning specifications. This can also be the existing ground, which has been checked for suitability.

When selecting the embedment materials and their grain size and any shoring/joists, observe the following:

- Pipe diameter
- Pipe material
- Pipe wall thickness
- Ground characteristics

In general, materials for the embedment should not contain any components larger than 22 mm. DIN EN 1610 must be complied with.

8.3.2 Pipe bedding

The pipe bedding is comprised of a bottom bedding layer and a top bedding layer. The pipe bedding has to completely fill up the trench width.

As per DIN EN 1610, a differentiation is made between three bedding types:

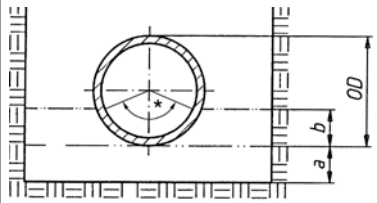
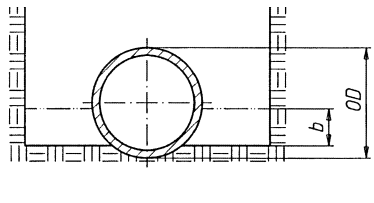
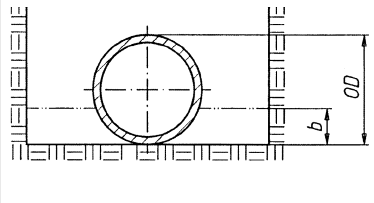
	Pipe bedding Type 1	Pipe bedding Type 2	Pipe bedding Type 3
Structure	 <p>* Bedding angle (2α) a Bottom intermediate bedding layer b Top bedding layer OD Pipe outer diameter</p>	 <p>b Top bedding layer OD Pipe outer diameter</p>	 <p>b Top bedding layer OD Pipe outer diameter</p>
Use	<ul style="list-style-type: none"> - Suitable for any embedment - Pipe must lie securely along its entire length 	<ul style="list-style-type: none"> - Ideal for even, relatively loose and fine-grain ground - Ground must permit support over the entire pipe length 	<ul style="list-style-type: none"> - Ideal for even, relatively fine-grain ground - Ground must permit support over the entire pipe length
Bottom bedding layer a	<ul style="list-style-type: none"> - Normal ground conditions: $a \geq 100$ mm - Rock or solid ground: $a \geq 150$ mm 	<ul style="list-style-type: none"> - Pipe lies directly on the trench bottom 	<ul style="list-style-type: none"> - Pipe lies directly on the trench bottom
Top bedding layer b	Specification of the thickness according to the static calculation	Specification of the thickness according to the static calculation	Specification of the thickness according to the static calculation

Tab. 8-1 Pipe bedding types

Special pipe bedding or support construction type

For a trench bottom with minimal pipe bedding supportive capacity, e.g. in the case of non-load-bearing ground like turf or quicksand, special measures are required, e.g.:

- replacing the ground with other construction materials
- supporting the pipeline with posts etc.

These types may only be used if their suitability has been verified by static calculations.

8.3.3 Filling

To prevent surface settling, side and main filling are to be put in place in accordance with the planning requirements.

8.3.4 Compacting

The degree of compacting must be according to static calculation and pipelines specifications.



- If necessary, compacting of the cover must be carried out by hand directly over the pipe.
- Mechanical compacting of the main filling cannot be carried out until a layer that is at least 30 cm thick is in place over the pipe apex.
- Selection of the compacting equipment, the number of compacting runs and the layer thickness to be compacted must be appropriate for to the material to be compacted and the pipeline.
- Compacting the main or side filling via silting is only permissible in exceptional cases with suitable cohesionless ground.

8.4 Building connections

Connections to the building (e.g. shafts) are to be made with joints. Special appropriate shaft liners are used here. The seal between the pipeline and the shaft liner is handled by the rubber sealing ring integrated in the shaft liner.

8.5 Leak test



The leak test must be carried out in accordance with DIN EN 1610.

The leak test is carried out after removal of the shoring material and after the trench filling.

Test with water

1. Carry out a visual check and close all openings securely.
2. Slowly fill pipe or defined pipe section with water and fully de-aerate.
3. Once the test pressure of 0.5 bar is reached, comply with a full fill time of 1 hour.
4. Then maintain the test pressure of 0.5 bar for 30 minutes.
If necessary, top up water.

The test has been passed if the topped-up water quantity per square meter of interior surface does not exceed the following values:

- Pipelines	0.15 litres
- Pipelines with shafts	0.2 litres
- Pipelines with shafts and inspection openings	0.4 litres

Test with air

Alternatively, the test can be carried out with air.



Danger of injury!

Due to the increased air pressure, cut-off components could be blown out. Ensure firm and sealed seating of the cut-off components.

The air test is carried out with two air pressures:

- Initial pressure corresponds to 110 % of test pressure
- Test pressure depends on test method and nominal size

1. Maintain initial pressure for approx. 5 minutes.
2. Then reduce air pressure to test pressure.
3. Start test time and record drop in pressure during the test time.

The test has been passed if the drop in pressure lies within the permissible range. The test parameters can be taken from DIN EN 1610/Table 3.

9 CERTIFICATIONS

RAUPIANO PLUS was approved by the following certification agencies and others:



Germany



Germany

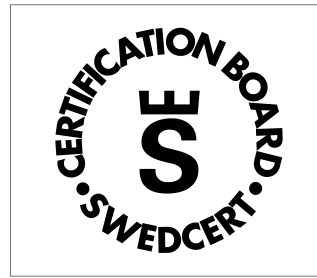

Sweden



Norway

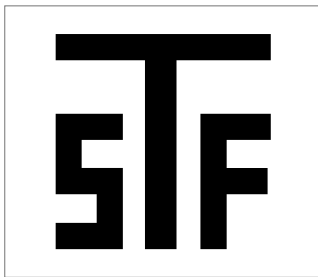

Finland



Russia



Denmark



Denmark



Poland



Austria



Hungary



Malaysia



Australia

10 TECHNICAL SPECIFICATIONS

Material	PP-MD mineral-reinforced (pipes and fittings)		
Size range	DN 40 – DN 200		
Area of application	Waste water pipes in buildings and laid underground inside and outside the building structure		
Chemical resistance	Polypropylene basis		in accordance with DIN 8078
	No waste water containing benzene		
	Seals made of SBR		DIN 4060, DIN EN 681-1
Application	Waste water with pH value 2 – 12 Waste water temperature up to 95°C (brief periods) or 90°C (continuous load)		
Density	Pipes	1.9 g/cm ³	
	Fittings	1.1 – 1.9 g/cm ³	
Ave. change in length	0.09 mm/m-k		DIN 53752
Ring rigidity	> 4 kN/m ²		DIN EN ISO 9969
Tensile strength	> 16 N/mm ²		DIN EN ISO 527-3
Breakage elongation	Approx. 150 %		DIN EN ISO 527-3
Modulus of elasticity in tension	Approx. 2,700 N/mm ²		DIN EN ISO 527-2
MFR 190/5	Approx. 1.7 g/10 min.		DIN EN ISO 1133
MFR 230/2,16	Approx. 0,82 g/10 min.		DIN EN ISO 1133
Seal	0.5 bar (5 m water column)		Test certificates for up to 1 bar on request
Pipe structure	Pipes features innovative three-layer structure		
	- Impact-resistant and shock-proof PP outer layer		
	- Highly rigid middle layer made of mineral-reinforced PP		
Fittings	- Abrasion-resistant and very slick inner layer		
	- Mass optimisation in redirection area for increased sound insulation		
			DN 90 – DN 160
Halogen components	Halogen-free (no F, Cl, Br, J)		
Connection	Push-fit socket with factory-installed lip sealing ring		
Fire behaviour	B2 (normally inflammable)		In accordance with DIN 4102
System compatibility	No adapters for HT or KG pipes required		
Standards	System test according to DIN EN 1451-1		
	Supplemental tests as per the requirements of the Deutsches Institut für Bautechnik (DIBt) in Berlin		
Sound insulation	Test as per DIN EN 14366, test reports from the Fraunhofer Institute for Building Physics:		
	P-BA 6/2006	with support attachment	Max. 17 dB(A) at 4 L/s
	P-BA 176/2006	with standard clamp	Max. 24 dB(A) at 4 L/s
Approval	Deutsches Institut für Bautechnik (DIBt)		ABZ 42.1-223
Independent monitoring	Süddeutsches Kunststoffzentrum (SKZ), Germany		
Fire load	The RAUPIANO PLUS fire load was determined by MPA. It is		
	- 14,992 kJ/kg		
	Transferred to a DN 110 RAUPIANO PLUS pipe:		
	- 7.9 kWh/m		
	- 28,464.8 kJ/m		

Tab. 10-1 Technical specifications

11 CHEMICAL RESISTANCE

Pipe and fitting

The specifications are used for the initial orientation of the chemical resistance of the material (not of the possible influence of the corrosive agent) and cannot simply be applied to all usage scenarios. Mechanical behaviour can be impaired in cases where tension and the presence of chemicals occur simultaneously (tension-fracture corrosion).

Reagent	Concentr. %	Temp. °C	RAU-PP
2-Propen-1-ol	96	20	r
	96	60	r
Acetaldehyde + acetic acid	90/10	20	–
Acetaldehyde, aqueous	40	40	r
Acetaldehyde, concentrated	100	20	–
Acetate ether	100	20	–
Acetic acid, aqueous	up to 25	40	r
	up to 25	60	r
	25–60	60	r
	80	40	r
Acetic acid, concentrated	95	40	–
Acetic anhydride	100	20	r
	100	40	cr
Acetone	100	60	cr
	100	20	r
Acetone, aqueous	traces	20	r
Acronal dispersions	com. avail.	20	–
Acronal solutions	com. avail.	20	–
Acrylic acid ethyl ester	100	20	–
Adipic acid, aqueous	saturated	20	r
	saturated	60	–
Aluminium chloride	diluted	40	r
	diluted	60	r
	saturated	60	r
Aluminium sulfate, aqueous	diluted	40	r
	diluted	60	r
	saturated	60	r
Alums, aqueous	diluted	40	r
	diluted	60	r
	saturated	60	r
Ammonia, gas	100	60	r
Ammonia, liquid	100	20	r
Ammonium chloride, aqueous	diluted	40	r
	diluted	60	r
	saturated	60	r
Ammonium fluoride, aqueous	up to 20	20	r
	up to 20	60	r
Ammonium hydroxide	warm sat.	40	r
	warm sat.	60	r
Ammonium nitrate, aqueous	diluted	40	r
	diluted	60	r
	saturated	60	r

Rubber sealing ring

The types of rubber used generally exhibit quite good chemical resistance, but components of esters, ketones and aromatic and chlorinated hydrocarbons in sewer water expand heavily, which can lead to damage of the connection. If in doubt, we recommend testing the suitability of the pipe, fitting and seal material in existing systems or have them checked in a laboratory. Contact our applications department if necessary.

Table legend

- r = resistant
- cr = conditionally resistant
- nr = not resistant
- = not tested

Reagent	Concentr. %	Temp. °C	RAU-PP
Ammonium sulfate, aqueous	diluted	40	r
	diluted	60	r
	saturated	60	r
Ammonium sulfide, aqueous	diluted	40	r
	diluted	60	r
	saturated	60	r
Aniline hydrochloride, aqueous	saturated	20	r
	saturated	60	r
Aniline, aqueous	saturated	20	r
	saturated	60	r
Aniline, pure	100	20	r
	100	60	r
Animal glue	custom. conc.	20	r
	custom. conc.	60	r
Anthraquinonesulfonic acid, aqueous	suspension	30	r
Antiformin, aqueous	2	20	–
Antimony chloride, aqueous	90	20	r
Arsenic acid, aqueous	diluted	40	r
	diluted	60	r
	80	40	r
Beef tallow emulsion, sulphonated	80	60	r
	com. avail.	20	–
Beer	com. avail.	20	r
Beer colouring agent	com. avail.	60	r
Benzaldehyde, aqueous	0,1	60	–
Benzene	100	20	cr
	any	20	r
	any	40	r
Benzoic acid, aqueous	any	60	r
	any	40	r
Bisulphite solution, w/ SO ₂	warm sat.	50	r
Bleaching liquor, containing 12.5 % active chlorine	usage conc.	40	–
	usage conc.	60	cr
Borax, aqueous	diluted	40	r
	diluted	60	r
	saturated	60	r
Boric acid, aqueous	diluted	40	r
	diluted	60	r
	saturated	60	r
Brandy	com. avail.	20	r
Bromine fumes	minimal	20	nr
Bromine, liquid	100	20	nr
Butadiene	100	60	–

Reagent	Concentr. %	Temp. °C	RAU-PP
Butane, gaseous	50	20	r
Butanediol	up to 100	20	–
Butanediol, aqueous	up to 10	20	r
	up to 10	40	r
	up to 10	60	r
	up to 100	20	r
Butanol	up to 100	40	r
	up to 100	60	cr
	up to 100	60	cr
Butyl acetate	100	20	cr
Butylene, liquid	100	20	–
Butylphenol	100	20	r
Butynediol	up to 100	40	–
Butyric acid, aqueous	20	20	r
	concentr.	20	r
Calcium chloride, aqueous	diluted	40	r
	diluted	60	r
	saturated	60	r
Calcium nitrate, aqueous	50	40	r
Carbolineum, aqueous	usage conc.	20	–
Carbon dioxide, aqueous under 8 atmospheric pressures	saturated	20	–
Carbon dioxide, dry	100	60	r
Carbon dioxide, moist	any	40	r
	any	60	r
Carbon disulfide	100	20	cr
Carbon tetrachloride, technical	100	20	nr
Caustic potash solution, aqueous	up to 40	40	r
	up to 40	60	r
	50/60	60	r
Caustic soda, aqueous	up to 40	40	r
	up to 40	60	r
	50/60	60	r
Chloramine, aqueous	diluted	20	–
Chloric acid, aqueous	1	40	–
	1	60	–
	10	40	–
	10	60	–
	20	40	–
20	60	–	
Chlorine water	saturated	20	cr
Chlorine, gaseous, dry	100	20	nr
Chlorine, gaseous, moist	0,5	20	nr
	1	20	nr
	5	20	nr
Chlormethyl	100	20	–
Chloroacetic acid (mono)	100	40	r
	100	60	–
Chloroacetic acid (mono) aqueous	85	20	r
Chlorosulfonic acid	100	20	nr
Chromic acid, aqueous	up to 50	40	–
	up to 50	60	cr
Chromic acid/Sulphuric acid/Water	50/15/35	40	nr
	50/15/35	60	nr
Cider	com. avail.	20	r
Citric acid, aqueous	up to 10	40	r
	up to 10	60	r
	saturated	60	r
Clophene	com. avail.	20	–
	com. avail.	60	–
Coconut fat alcohol	100	20	r
	100	60	cr

Reagent	Concentr. %	Temp. °C	RAU-PP
Copper fluoride, aqueous	2	50	r
Copper sulfate, aqueous	diluted	40	r
	diluted	60	r
	saturated	60	r
Cresol, aqueous	up to 90	45	–
Crotonaldehyde	100	20	r
Cyclohexanol	100	20	r
Cyclohexanone	100	20	r
Cyclohexanone	100	20	r
Densodrin W	com. avail.	60	–
Dextrin, aqueous	saturated	20	r
	18	60	r
Dextrose, aqueous	saturated	20	b
	saturated	60	b
Diethylether	100	20	cr
Diglycol acid, aqueous	30	60	r
	saturated	20	r
Dimethyl sulfate, aqueous	up to 50	20	r
	up to 50	40	r
	100	40	–
	100	60	–
Dimethylamine, liquid	100	30	–
Disulfuric acid	10	20	nr
Ethanol (fermentation mash)	common	40	r
	common	60	–
Ethanol, aqueous	any	20	r
	96	60	r
Ethanol, denatured (with 2 % toluene)	96	20	cr
Ethanol+ acetic acid (fermentation mash)	common	20	r
Ethyl acetate	100	20	cr
	100	60	nr
Ethylene chloride	100	20	nr
Ethylene oxide, liquid	100	20	–
Exhaust gas, w/ H2CO3	any	60	r
Exhaust gas, w/ HF	traces	60	r
Exhaust gas, w/ NOX	traces	60	r
	higher	60	–
Exhaust gases, w/ H2S2O7	lower	20	–
	higher	20	nr
Exhaust gases, w/ H2SO4, moist	any	60	r
Exhaust gases, w/ HCl	any	60	r
Exhaust gases, w/ SO2	lower	60	r
	50	50	–
Fatty acids	100	60	cr
Ferric chloride, aqueous	up to 10	40	r
	up to 10	60	r
	saturated	60	r
Fertilizer salts, aqueous	up to 10	40	r
	up to 10	60	r
	saturated	60	r
Fluorsilicic acid, aqueous	up to 32	60	–
Formaldehyde, aqueous	diluted	40	r
	diluted	60	r
Formic acid	40	30	r
	100	20	r
Formic acid, aqueous	100	60	cr
	up to 50	40	r
50	60	r	

Reagent	Concentr. %	Temp. °C	RAU-PP
Frigen	100	20	cr
Fruit pulp	custom. conc.	20	r
Glucose, aqueous	saturated	20	r
	saturated	60	r
Glycerine, aqueous	any	60	r
Glycine, aqueous	10	40	r
Glycol, aqueous	com. avail.	60	r
Glycolic acid, aqueous	37	20	r
Hexantriol	com. avail.	60	r
Hydrobromic acid, aqueous	up to 10	40	r
	up to 10	60	r
	48	60	r
Hydrochloric acid, aqueous	up to 30	40	r
	up to 30	60	r
	over 30	20	r
	over 30	60	r
Hydrofluoric acid, aqueous	up to 40	20	r
	40	60	r
	60	20	r
	70	20	r
Hydrogen	100	60	r
Hydrogen peroxide, aqueous	up to 30	20	r
	up to 20	50	r
Hydrogen phosphide	100	20	–
Hydrogen sulfide, dry	100	60	r
Hydrogen sulfide, aqueous	warm sat.	40	r
	warm sat.	60	r
Hydrosulfite, aqueous	up to 10	40	r
	up to 10	60	r
Hydroxylamine sulfate, aqueous	up to 12	35	r
Lactic acid, aqueous	up to 10	40	r
	up to 10	60	r
	90	60	r
Lead acetate, aqueous	warm sat.	50	r
	diluted	40	r
	diluted	60	r
	saturated	60	r
Lead tetraethyl	100	20	r
Liqueurs	com. avail.	20	r
Magnesium chloride, aqueous	diluted	40	r
	diluted	60	r
	saturated	60	r
Magnesium sulfate, aqueous	diluted	40	r
	diluted	60	r
	saturated	60	r
Maleic acid, aqueous	saturated	40	r
	saturated	60	r
	35	40	r
Malic acid, aqueous	1	20	r
Mersol D	custom. conc.	40	–
Methanol	100	40	r
	100	60	r
Methyl amine	32	20	r
Methylene chloride	100	20	nr
Milk	com. avail.	20	r
Mixed acid (Sulfuric acid/Nitric acid/Water)	48/49/3	20	nr
	48/49/3	40	nr
	50/50/0	20	nr
	50/50/0	40	nr
	10/20/70	50	cr
	10/87/3	20	nr
50/31/19	30	nr	

Reagent	Concentr. %	Temp. °C	RAU-PP
Molasses	custom. conc.	20	r
	custom. conc.	60	r
Molasses wort	custom. conc.	60	r
Mowilith D	com. avail.	20	–
Nekal, BX, aqueous	diluted	40	–
	diluted	60	–
Nickel sulfate, aqueous	diluted	40	r
	diluted	60	r
	saturated	60	r
Nicotine compounds, aqueous	usage conc.	20	–
Nicotine, aqueous	usage conc.	20	–
Nitric acid, aqueous	up to 30	50	r
	30/50	50	nr
	98	20	nr
	98	60	nr
Nitrous gasses	concentr.	20	r
	concentr.	60	–
Oils and greases	com. avail.	60	cr
Oleic acid	com. avail.	60	cr
Oleum vapour	lower	20	cr
	higher	20	nr
Oxalic acid, aqueous	diluted	40	r
	diluted	60	r
	saturated	60	r
Oxygen	any	60	–
Ozone	100	20	cr
	10	30	r
Palm kernel oil acid	100	60	–
Paraffin emulsions	com. avail.	20	–
	com. avail.	40	–
Perchloric acid, aqueous	up to 10	40	r
	up to 10	60	r
	saturated	60	–
Petrol	100	60	nr
Petrol-benzene mixture	80/20	20	cr
Phenol, aqueous	up to 90	45	r
	1	20	–
Phenylhydrazine	100	20	cr
	100	60	–
Phenylhydrazine hydrochloride, aqueous	saturated	20	–
	saturated	60	–
Phosgene, aqueous	100	20	nr
Phosgene, gaseous	100	20	cr
	100	60	cr
Phosphoric acid, aqueous	up to 30	40	r
	up to 30	60	r
	40	60	r
	80	20	r
80	60	r	
Phosphorous pentoxide	100	20	r
Phosphorous trichloride	100	20	r
Photographic developers	com. avail.	40	r
Photographic emulsions	any	40	–
Photographic fixers	com. avail.	40	r
Picric acid, aqueous	1	20	r
Potash, aqueous	saturated	40	–
Potassium borate, aqueous	1	40	r
	1	60	r

Reagent	Concentr. %	Temp. °C	RAU-PP
Potassium bromate, aqueous	up to 10	40	r
	up to 10	60	r
Potassium bromide, aqueous	diluted	40	r
	diluted saturated	60 60	r r
Potassium chlorate, aqueous	1	40	r
	1	60	r
Potassium chloride, aqueous	diluted	40	r
	diluted saturated	60 60	r r
Potassium chromate, aqueous	40	20	r
Potassium cyanide, aqueous	up to 10	40	r
	up to 10 saturated	60 60	r r
Potassium dichromate, aqueous	40	20	r
Potassium ferrocyanide	diluted	40	r
Potassium ferrocyanide, aqueous	diluted	60	r
	saturated	60	r
Potassium nitrate, aqueous	diluted	40	r
	diluted saturated	60 60	r r
Potassium permanganate, aqueous	up to 6	20	r
	up to 6	40	r
	up to 6	60	r
	up to 18	40	–
Potassium persulfate, aqueous	diluted	40	r
	diluted saturated saturated	60 40 60	r r r
Propane, gaseous	100	20	–
Propane, liquid	100	20	–
Propargyl alcohol, aqueous	7	60	r
Pure acetic acid	100	20	r
	100	40	r
Ramasite	com. avail. com. avail.	20 40	– –
Roaster gases, dry	any	60	r
Seawater	–	40	r
	–	60	r
Silicic acid, aqueous	any	60	r
Silver nitrate, aqueous	up to 8	40	r
	up to 8	60	r
Soap solution, aqueous	concentrated	20	r
	concentrated	60	r
Soda, aqueous	diluted	40	r
	diluted saturated	60 60	r r
Sodium benzoate, aqueous	up to 10	40	r
	up to 10 36	60 60	r r
Sodium chlorate, aqueous	up to 10	40	r
	up to 10 saturated	60 60	r r
Sodium chlorite, aqueous	50	20	r
	diluted	60	nr
Sodium hydrosulfite, aqueous	diluted	40	r
	diluted saturated	60 60	r r
Sodium hypochlorite, aqueous	diluted	20	r

Reagent	Concentr. %	Temp. °C	RAU-PP
Sodium sulfide, aqueous	diluted	40	r
	diluted	60	r
	saturated	60	r
Spirits	com. avail.	20	r
Starch syrup	custom. conc.	60	r
Starch, aqueous	any	40	r
	any	60	r
Stearic acid	100	60	cr
Sulphur dioxide, aqueous under 8 atmospheric pressures	saturated	20	–
	100	–10	–
Sulphur dioxide, liquid	100	20	r
	100	60	r
	any	40	r
Sulphur dioxide, moist and aqueous	50	50	r
	any	60	r
Sulphur dioxide, dry	any	60	r
	up to 40 up to 40	40 60	r r
Sulphuric acid, aqueous	70	20	r
	70	60	cr
	80–90	40	cr
	96	20	r
Table salt, aqueous	96	60	nr
	diluted	40	r
Tallow	diluted	60	r
	saturated	60	r
Tanigan extra A, aqueous	100	20	r
Tanigan extra B, aqueous	100	60	r
Tanigan extra D, aqueous	any	20	–
	saturated saturated	40 60	– –
Tanigan F, aqueous	saturated	60	–
Tanigan U, aqueous	saturated saturated	40 60	– –
Tanning extracts, cellul.	common	20	r
Tanning extracts, natural	common	20	r
Tartaric acid, aqueous	up to 10	40	r
	up to 10 saturated	60 60	r r
Thionyl chloride	100	20	nr
Tin (II) chloride, aqueous	diluted	40	r
	diluted saturated	60 60	r r
Toluene	100	20	nr
Trichloroethylene	100	20	nr
Triethanolamine	100	20	r
Trilone	com. avail.	60	–
Trimethylolpropane, aqueous	up to 10	40	–
	up to 10 com. avail. com. avail.	60 40 60	– r r
Urea, aqueous	up to 10	40	r
	up to 10 33	60 60	r r
Urine	normal	40	r
	normal	60	r
Vinegar (wine vinegar)	com. avail.	40	r
	com. avail.	50	r
	com. avail.	60	r

Reagent	Concentr. %	Temp. °C	RAU- PP
Vinyl acetate	100	20	r
Water	100		r
	100		r
Wax alcohol	100	60	cr
Wine, red and white	com. avail.	20	r
Xylene	100	20	nr
Yeast wort	custom. conc.	40	r
	custom. conc.	60	r
Zinc chloride, aqueous	diluted	40	r
	diluted	60	r
	saturated	60	r
Zinc sulphate, aqueous	diluted	40	r
	diluted	60	r
	saturated	60	r

12 STANDARDS, REGULATIONS AND GUIDELINES

DIN 1054

Ground – Verification of the safety of earthworks and foundations

DIN 1055 Part 2

Design loads for buildings; soil characteristics; specific weight, angle of friction, cohesion, angle of wall friction

DIN 1986

Drainage systems on private ground

DIN 4060

Pipe joint assemblies with elastomer seals for use in drains and sewers, requirements and tests

DIN 4102

Fire behaviour of building materials and elements

DIN 4109

Sound insulation in buildings

DIN 4124

Excavations and trenches – Slopes, planking and strutting, breadths of working spaces

DIN EN 476

General requirements for components used in discharge pipes, drains and sewers for gravity systems

DIN EN 681

Elastomeric seals

Material requirements for pipe joint seals used in water and drainage applications

DIN EN 752

Drain and sewer systems outside buildings

DIN EN 1451

Plastic piping systems for soil and waste discharge (low and high temperature) within the building structure – Polypropylene (PP)

DIN EN 1610

Construction and testing of drains and sewers

DIN EN 12056

Gravity drainage systems inside buildings

VDI guideline 4100

Sound insulation in residential buildings – Criteria for planning and assessment

General building construction approval from the German Institute of Building Technology (DIBt)

Approval Z-42.1-223

RAUPIANO PLUS waste pipes and fittings

Approval Z-19.17-1662

REHAU PLUS fireproofing collar system

Approval Z-19.17-1363

REHAU “kompakt” fireproofing collar system

Approval Z-19.17-1268

REHAU angled fireproofing collar system

Assembly times - sanitation

German Plumbing, Sanitation and Heating Guild in Munich

6. Fully revised and expanded edition, 2005

RAUCAD software from REHAU EN 12056

ATV-DVWK-A 127

Guideline for static calculation of waste water pipework

Insofar as the intended application deviates from that described in the relevant Technical Information brochure, the user must consult REHAU and must receive express written consent from REHAU before commencing this utilization. If the user fails to do so, the sole responsibility for the utilization shall lie with the individual user. In this case, the application, use and processing of products are beyond our control. Should a case of liability arise, however, this shall be limited to the value of the goods delivered by us and used by you in all cases of damage. Claims arising from granted guarantees shall become invalid in the case of intended applications that are not described in the Technical Information brochures.

This document is protected by copyright. All rights based on this are reserved. No part of this publication may be translated, reproduced or transmitted in any form or by any similar means, electronic or mechanical, photocopying, recording or otherwise, or stored in a data retrieval system.